

EI-450 Series

220V Class 1HP~7½ HP

440V Class 1HP~10 HP

**Read this manual carefully before installing, wiring,
operating, servicing or inspecting the drive.
Keep this manual within easy reach for quick reference.**

Thank you for purchasing Eric-450 Variable Speed Drives!

SAFETY INSTRUCTIONS

- Always follow safety instructions to prevent accidents and potential hazards from occurring.

- In this manual, safety messages are classified as follows:



WARNING

Improper operation may result in serious personal injury or death.



CAUTION

Improper operation may result in slight to medium personal injury or property damage.

- Throughout this manual we use the following two illustrations to make you aware of safety considerations:



Identifies potential hazards under certain conditions.
Read the message and follow the instructions carefully.



Identifies shock hazards under certain conditions.
Particular attention should be directed because dangerous voltage may be present.

- Keep operating instructions handy for quick reference.
- Read this manual carefully to maximize the performance of EI-450 series inverter and ensure its safe use.



WARNING

- **Do not remove the cover while power is applied or the unit is in operation.**
Otherwise, electric shock could occur.
- **Do not run the inverter with the front cover removed.**
Otherwise, you may get an electric shock due to high voltage terminals or charged capacitor exposure.
- **Do not remove the cover except for periodic inspections or wiring, even if the input power is not applied.**
Otherwise, you may access the charged circuits and get an electric shock.

-
- **Wiring and periodic inspections should be performed at least 10 minutes after disconnecting the input power and after checking the DC link voltage is discharged with a meter (below DC 30V).**
Otherwise, you may get an electric shock.
 - **Operate the switches with dry hands.**
Otherwise, you may get an electric shock.
 - **Do not use the cable when its insulating tube is damaged.**
Otherwise, you may get an electric shock.
 - **Do not subject the cables to scratches, excessive stress, heavy loads or pinching.**
Otherwise, you may get an electric shock.



CAUTION

- **Install the inverter on a non-flammable surface. Do not place flammable material nearby.**
Otherwise, fire could occur.
- **Disconnect the input power if the inverter gets damaged.**
Otherwise, it could result in a secondary accident and fire.
- **After the input power is applied or removed, the inverter will remain hot for a couple of minutes.**
Otherwise, you may get bodily injuries such as skin-burn or damage.
- **Do not apply power to a damaged inverter or to an inverter with parts missing even if the installation is complete.**
Otherwise, electric shock could occur.
- **Do not allow lint, paper, wood chips, dust, metallic chips or other foreign matter into the drive.**
Otherwise, fire or accident could occur.

OPERATING PRECAUTIONS

(1) Handling and installation

- Handle according to the weight of the product.
- Do not stack the inverter boxes higher than the number recommended.
- Install according to instructions specified in this manual.
- Do not open the cover during delivery.

-
- Do not place heavy items on the inverter.
 - Check the inverter mounting orientation is correct.
 - Do not drop the inverter, or subject it to impact.
 - Use the Type 3 grounding method for 220 V class and special Type 3 for 440V class. (Ground impedance: Below 100 ohm).
 - Take protective measures against ESD (Electrostatic Discharge) before touching the PCB for inspection or installation.
 - Use the inverter under the following environmental conditions:

Environment	Ambient temperature	- 10 ~ +50 (non-freezing)
	Relative humidity	90% RH or less (non-condensing)
	Storage temperature	- 20 ~ +60
	Location	Protected from corrosive gas, combustible gas, oil mist or dust
	Altitude, Vibration	Max. 1,000m above sea level, Max. 9.8m/sec ² (1.0G) or less

(2) Wiring

- Do not connect a power factor correction capacitor, surge suppressor, or RFI filter to the output of the inverter.
- The connection orientation of the output cables U, V, W to the motor will affect the direction of rotation of the motor.
- Incorrect terminal wiring could result in the equipment damage.
- Reversing the polarity (+/-) of the terminals could damage the inverter.
- Only authorized personnel familiar with RICH ELECTRIC inverter should perform wiring and inspections.
- Always install the inverter before wiring. Otherwise, you may get an electric shock or have bodily injury.

(3) Test run

- Check all constants during operation. Changing constant values might be required depending on the load.
- Always apply permissible range of voltage to the each terminal as indicated in this manual. Otherwise, it could lead to inverter damage.

(4) Operation precautions

- When the Auto restart function is selected, stay away from the equipment as a motor will restart suddenly after an alarm stop.
- The “**Stop**” key on the keypad is valid only when the appropriate function setting has been made. Prepare an emergency stop switch separately.

-
- If an alarm reset is made with the reference signal present, a sudden start will occur. Check that the reference signal is turned off in advance. Otherwise an accident could occur.
 - Do not modify or alter anything inside the inverter.
 - Motor might not be protected by electronic thermal function of inverter.
 - Do not use a magnetic contactor on the inverter input for frequent starting/stopping of the inverter.
 - Use a noise filter to reduce the effect of electromagnetic interference. Otherwise nearby electronic equipment may be affected.
 - In case of input voltage unbalance, install AC reactor. Power factor capacitors and generators may become overheated and damaged due to potential high frequency noise transmitted from inverter.
 - Use an insulation-rectified motor or take measures to suppress the micro surge voltage when driving 440V class motor with inverter. A micro surge voltage attributable to wiring constant is generated at motor terminals, and may deteriorate insulation and damage motor.
 - Before operating unit and prior to user programming, reset user constants to default settings.
 - Inverter can easily be set to high-speed operations, verify capability of motor or machinery prior to operating unit.
 - Stopping torque is not produced when using the DC-Break function. Install separate equipment when stopping torque is needed.

(5) Fault prevention precautions

- Provide a safety backup such as an emergency brake which will prevent the machine and equipment from hazardous conditions if the inverter fails.

(6) Maintenance, inspection and parts replacement

- Do not conduct a megger (insulation resistance) test on the control circuit of the inverter.
- Refer to Chapter 5 for periodic inspection (parts replacement).

(7) Disposal

- Handle the inverter as an industrial waste when disposing of it.

(8) General instructions

- Many of the diagrams and drawings in this instruction manual show the inverter without a circuit breaker, a cover or partially open. Never run the inverter like this. Always place the cover with circuit breakers and follow this instruction manual when operating the inverter.

CONTENTS

USER GUIDE	2
CHAPTER 1 INSTALLATION	9
Inspection.....	9
Environmental Conditions	9
Mounting.....	9
Other Precautions	10
Dimension	11
Standard Wiring	14
Terminal Description.....	15
Precautions on Wiring.....	16
Grounding.....	16
Wiring and Terminal Screw Sizes.....	18
Power and Motor Connection.....	18
Control Terminals.....	19
CHAPTER 2 TEST RUN	22
Test Run.....	22
Simple Operator (RCUS-450) User Instruction.....	24
Digital Operator (RCU-450/RCU-450P) User Instruction.....	26
LED Display and User Instruction of Digital Operator RCU-450.....	28
Simple Run Setting	33
CHAPTER 3 CONSTANTS LIST	34
Constants List (Constants F01-F79).....	34~42
Initial Settings That Change with The Inverter Capacity	42
CHAPTER 4 PROGRAMMING FEATURES	43
Constants F01-F79	43~85
CHAPTER 5 MAINTENANCE AND INSPECTION	86
Periodical Inspection	86
Part Replacement.....	86
CHAPTER 6 FAULT DIAGNOSIS	87
Protective and Diagnostic Functions.....	87
Alarm Display.....	87
Fault Display.....	91
APPENDIX-Recommended Peripheral Devices	96

Standard Specification

Voltage Class		220V class single-phase					220V class 3-phase					440V class 3-phase					
Model EI-450-		P2L	P4L	S1L	S2L	S3L	01L	02L	03L	05L	07L	01H	02H	03H	05H	07H	10H
Max. Application Motor Output (HP)		1/4	1/2	1	2	3	1	2	3	5	7.5	1	2	3	5	7.5	10
Output Features	Rated Output Current (A)	1.6	3	5	8	11	5	8	11	18	25	2.5	4	6	8	15	18
	Max. Output Voltage (V)	3-phase 200~230V (Proportional to input voltage)					3-phase 200~230V (Proportional to input voltage)					3-phase 380~460V (Proportional to input voltage)					
	Max. Output Frequency (Hz)	400Hz (Programmable)															
Power Supply	Rated Input Voltage and Frequency	Single-phase 200~230V 50/60 Hz					3-phase 200~230V 50/60 Hz					3-phase 380~460V 50/60 Hz					
	Allowable Voltage Fluctuation	-15 ~ +10%															
	Allowable Frequency Fluctuation	±5%															
Control Features	Control Method	Sine wave PWM (V/F control)															
	Frequency Control Range	0.1 ~ 400Hz															
	Frequency Accuracy (Temperature Change)	Digital reference : ± 0.01%(-10 ~ +50) Analog reference : ± 0.5% (25 ±10)															
	Frequency Setting Resolution	Digital reference: 0.1Hz (less than 100Hz) , 1Hz(100Hz or more) Analog reference: 1/1000 of max. output frequency															
	Output Frequency Resolution	0.01 Hz															
	Overload Capacity	150% rated output current for one minute															
	Frequency Reference Signal	DC0 ~ +10V(20K), 4 ~ 20mA(250), 0 ~ 20mA(250) Frequency setting potentiometer (Selectable)															
	Accel/Decel Time	0.0~999sec. (2 accel/dec. time are independently programmed)															
	Braking Torque	Short-term average deceleration torque 1HP:100% or more , 2HP: 50% or more , 3HP: 20% or more Continuous regenerative torque: Approx. 20%(150% with optional braking resistor, braking transistor built-in)															
V/F Characteristics	Possible to program any V/F pattern																
Protective Features	Motor Overload Protection	Electronic thermal overload relay															
	Instantaneous Overcurrent	Motor coasts to a stop at approx. 200% of inverter rated current															
	Overload	Motor coasts to a stop after 1 minute at 150% of inverter rated output current															
	Overvoltage	Motor coasts to a stop if DC bus voltage exceeds 410V(220VClass) Motor coasts to a stop if DC bus voltage exceeds 820V(440VClass)															
	Undervoltage	Motor coasts to a stop if DC bus voltage is less than 200V(220VClass) Motor coasts to a stop if DC bus voltage is less than 400V(440V Class)															
	Momentary Power Loss	Following items are selectable: Stops if power loss is 15ms or longer Continuous operation if power loss is approx. 0.5s or shorter															
	Cooling Fin Overheat	Protected by electronic circuit															
	Stall prevention level	Can be set individual level during accel/dec. provided/not provided available during coast to a stop															
	Cooling Fan Fault	Protected by electronic circuit (fan lock detection)															
	Ground Fault	Protected by electronic circuit (overcurrent level)															
Power Charge Indication	ON until the DC bus voltage becomes 50V or less																

Other Functions	Multi-function input	Four of the following input signals are selectable: Forward/reverse run (3-wire sequence), external fault, fault reset , 8-step speed operation , jog command, accel/decel time select, external baseblock, speed search command, accel/decel hold command, LOCAL/REMOTE selection, communication/control circuit terminal selection, emergency stop fault, emergency stop alarm UP/DOWN command, self-test.
	Multi-function output	Following ouput signals (IC contact) are selectable: Fault, running, zero speed, at frequency, frequency detection (output frequency or set value), during undervoltage detection, minor error, during baseblock, operation mode, inverter run ready, during fault retry, during UV, during speed search, data output through communication.
	Standard Function	Full-range automatic torque boost, slip compensation, DC injection braking current/time at start/stop, frequency reference bias/gain, MODBUS communications (RS-485/422, max. 19.2KBPS), constants copy, frequency reference with built-in potentiometer for input frequency reference.
	Digital Operator	RCUS-450 Simple operator : Available to set frequency reference, operating run/stop function (Standard). RCU-450 Digital operator : Available to monitor frequency reference, output frequency, output current, modify constants and operating run/stop function (Optional). RCU-450P Digital operator : Available to monitor and set the frequency reference, output frequency and modify constants, constants COPY , and operating run/stop function (Optional).
	Terminals	Main circuit: screw terminals Control circuit: plug-in screw terminal
	Wiring Distance between Inverter and Motor	100M or less
Enclosure		IP20
Cooling Method		Forced air cooling
Environmental Conditions	Ambient Temperature	Open chassis -10 ~ +50
	Humidity	90%RH or less (non-condensing)
	Storage Temperature*1	-20 ~ +60
	Location	Indoor (free from corrosive gases or dust)
	Elevation	1000M or less
	Vibration	Up to 9.8m/S ² (1G) at 10 ~ 20Hz Up to 2m/S ² (0.2G) at 20 ~ 50Hz

*1 Storage Temperature during shipping (for short period).

CHAPTER 1 INSTALLATION

Inspection

Inspect the inverter for any damage that may have occurred during shipping. Check the nameplate on the EI-450 inverter. Verify the inverter unit is the correct one for the application. The numbering system of the inverter is as shown below.

EI- 450 - 01 L

<u>ERIC INVERTER</u>	<u>APPLICABLE MOTOR CAPACITY</u>	<u>INPUT VOLTAGE</u>
	P2 :1/4HP (200W)	L : 220 V Class
	P4 :1/2HP (400W)	H : 440 V Class
	01 :1 HP	
	02 :2 HP	
	03 :3 HP	
	05 :5 HP	
	07 :7.5 HP	
	10 :10 HP	
	S1 :1HP (single-phase input)	
	S2 :2HP (single-phase input)	
	S3 :3HP (single-phase input)	
	S5 :5HP (single-phase input)	

Environmental Conditions

Verify the ambient condition for the mounting location.

- Ambient temperature should not be below -10 or exceed 50 .
- Relative humidity should be less than 90% (non-condensing).
- Altitude should be below 3,300ft (1,000m).

Do not mount the inverter in direct sunlight and isolate it from excessive vibration.

Mounting

The inverter must be mounted vertically with sufficient horizontal and vertical space between adjacent equipment (A= Over 6" (150mm), B= Over 2"(50mm)).

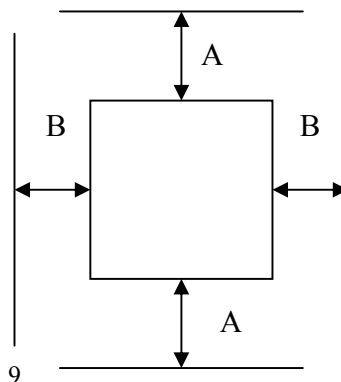

Other Precautions

Do not carry the inverter by the front cover.

Do not install the inverter in a location where excessive vibration is present. Be cautious when installing on presses or moving equipment.

The life span of the inverter is greatly affected by the ambient temperature. Install in a location where temperature are within permissible limits (-10 ~ +50).

The inverter operates at high-temperatures - install on a non-combustible surface.

Do not install the inverter in high-temperature or high-humidity locations.

Do not install the inverter in a location where oil mist, combustible gas, or dust is present. Install the inverter in a clean location or in an enclosed panel, free of foreign substance.

When installing the inverter inside a panel with multiple inverters or a ventilating fan, use caution.

If installed incorrectly, the ambient temperature may exceed specified limits.

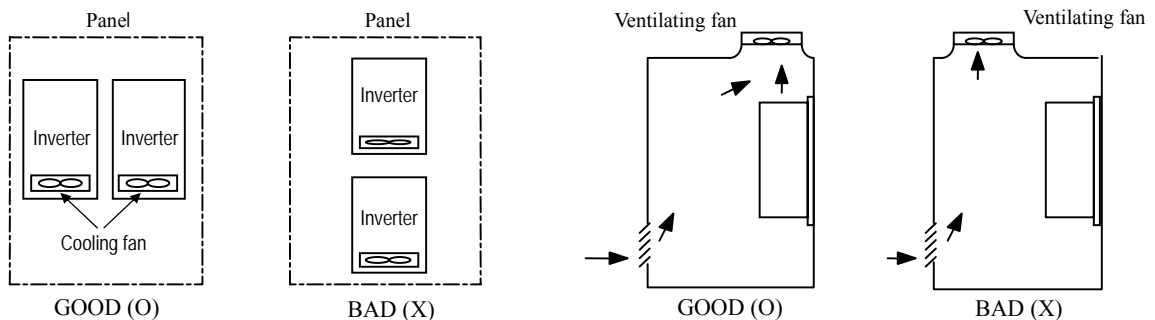

[When installing several inverters in a panel]

[When installing a ventilating fan in a panel]

Install the inverter using screws or bolts to insure the inverter is firmly fastened.

Dimension

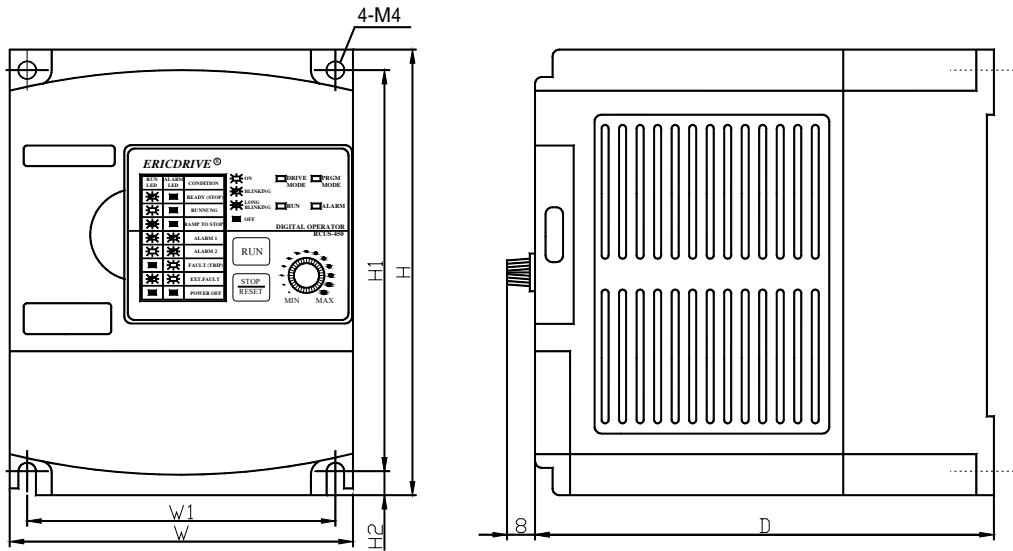

Fig.1

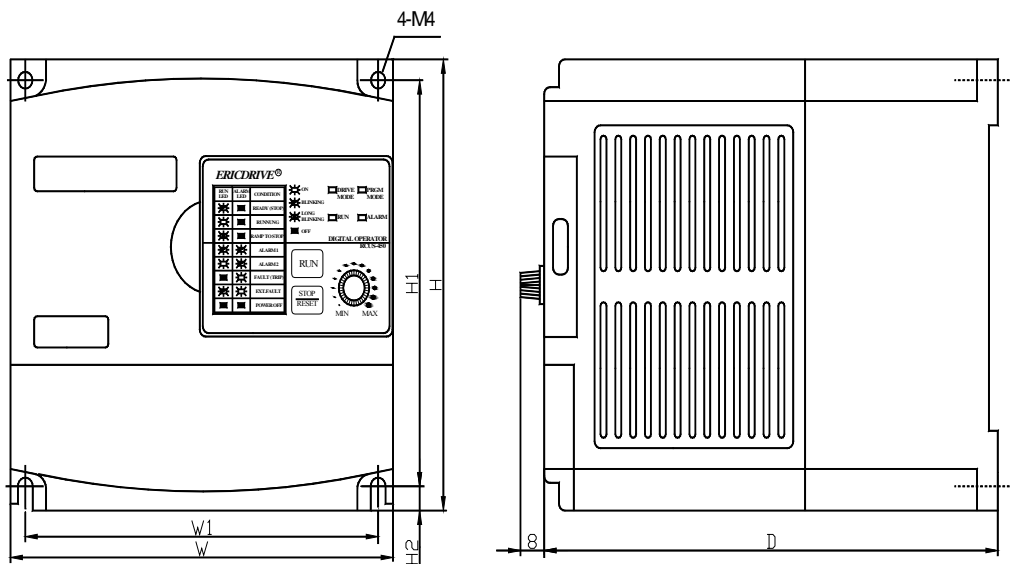

Fig.2

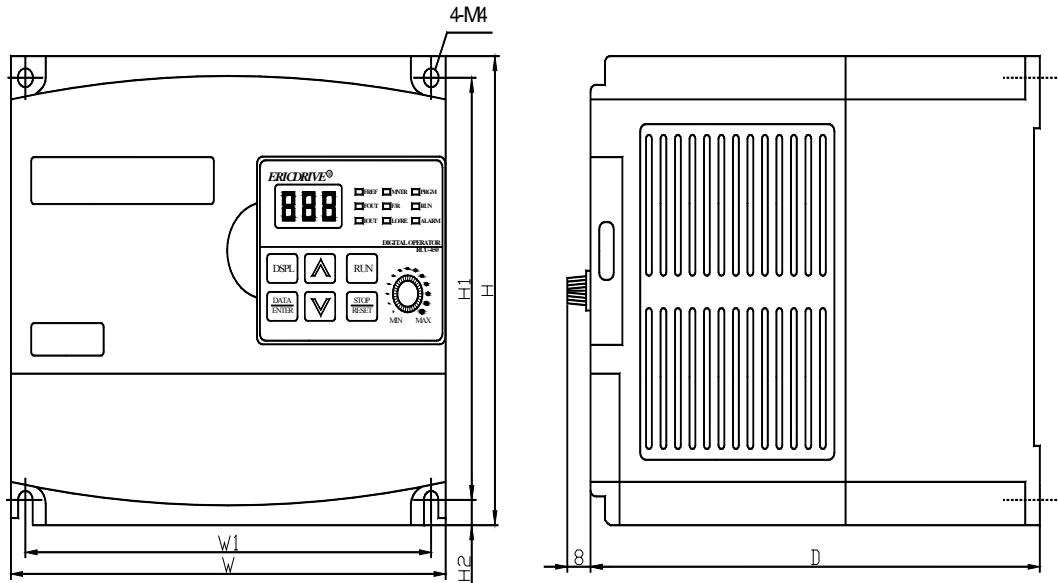

Fig.3

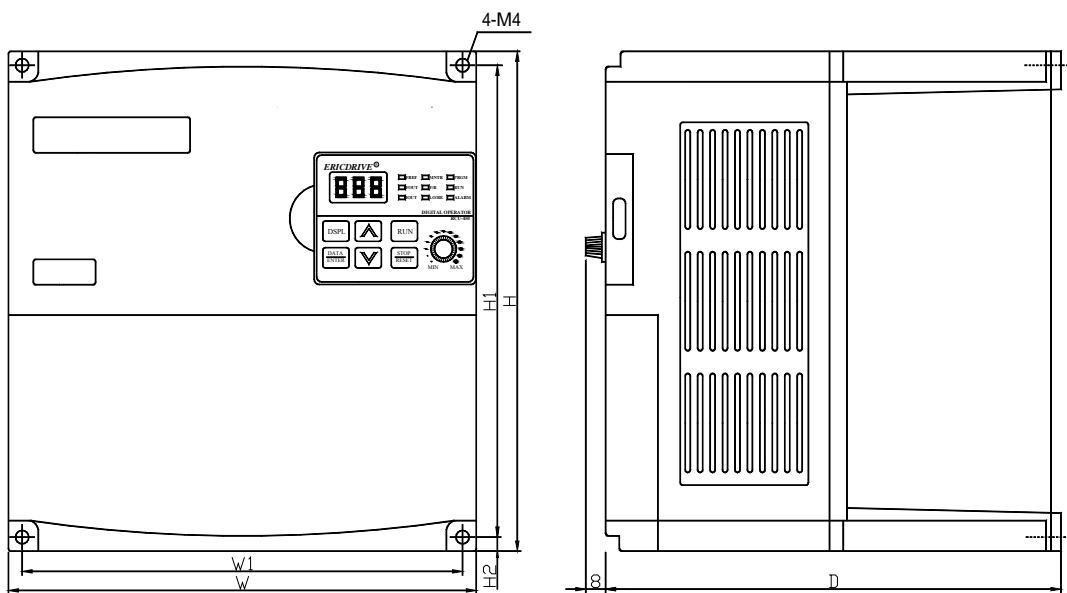
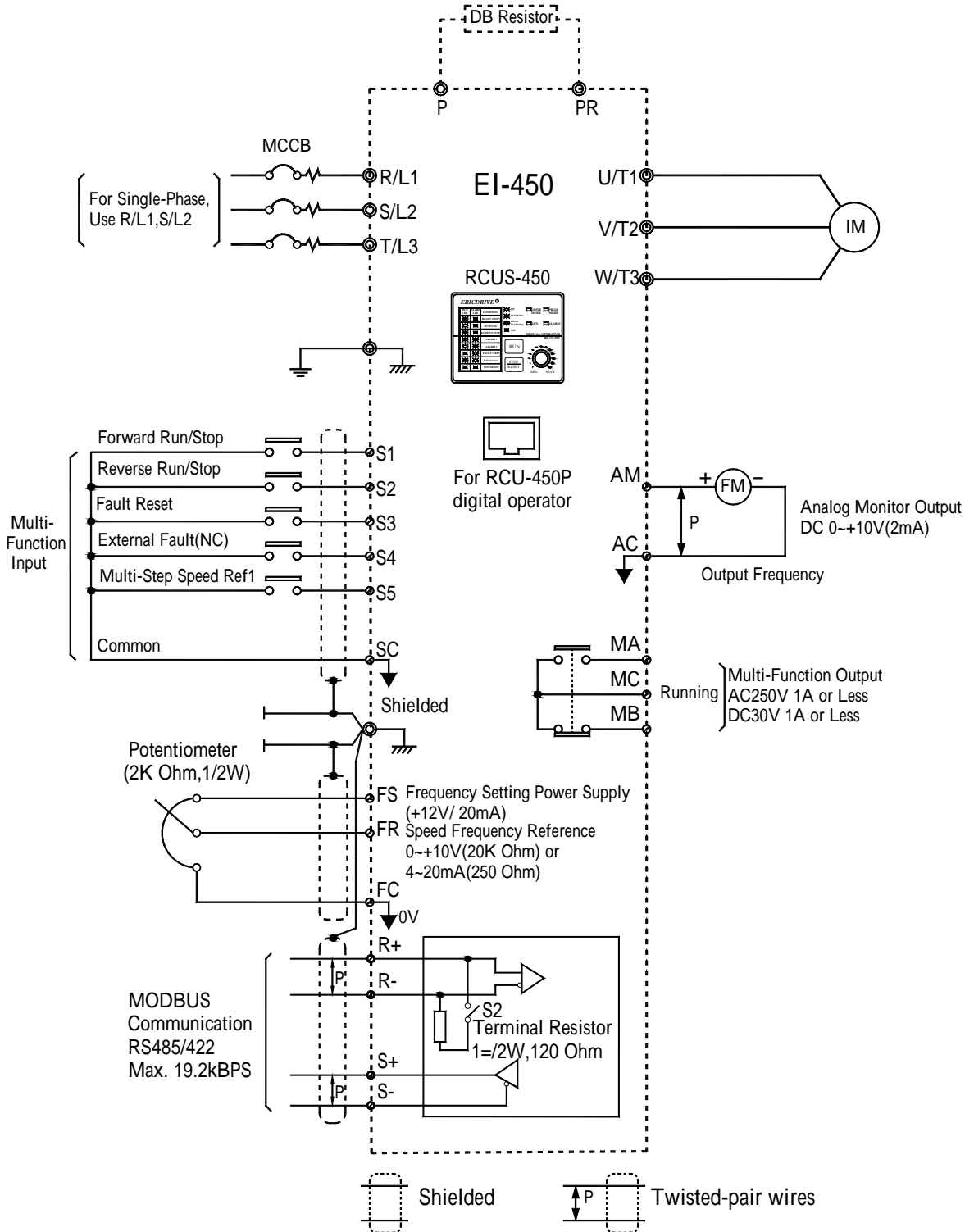

Fig.4

Dimension in mm/Mass in kg

Voltage Class	Capacity (HP)	W	H	D	W1	H1	H2	Mass	Fig.
220V single-Phase	1HP	98	130	131	88	117	7	0.9	1
	2HP	129	130	153	117	118	6	1.5	2
	3HP	150	130	155	137	117	7	1.8	3
220V 3-Phase	1HP	98	130	131	88	117	7	0.9	1
	2HP	129	130	153	117	118	6	1.5	2
	3HP	150	130	155	137	117	7	1.8	3
	5HP								
	7.5HP	187	198	186	175	186	5	5.0	4
440V 3-Phase	1HP	98	130	131	88	117	7	0.9	1
	2HP	129	130	153	117	118	6	1.5	2
	3HP	150	130	155	137	117	7	1.8	3
	5HP								
	7.5HP	187	198	186	175	186	5	5.0	4
	10HP								

Standard Wiring



Terminal Description

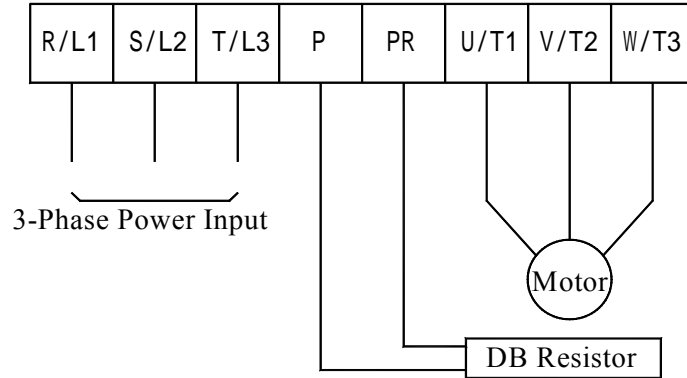

Symbols	Functions
R/ L1	AC line input terminals 3(1) phase, 200 ~ 230V AC for 220V class units and 380 ~ 460V AC for 440V class units.
S/ L2	
T/ L3	
U/ T1	3-Phase output terminals to motor
V/ T2	
W/ T3	
P	Dynamic braking resistor connection terminals
PR	



WARNING

Normal stray capacitance between the inverter chassis and the power devices inside the inverter and AC line can provide a high impedance shock hazard. Do not apply power to the inverter if the inverter frame is not grounded.

Precautions on Wiring

The internal circuits of the inverter will be damaged if the incoming power is connected and applied to output terminals (U, V, W).

Use ring terminals with insulated caps when wiring the input power and motor wiring.

Do not leave wire fragments inside the inverter. Wire fragments can cause faults, breakdowns, and malfunctions.

For input and output, use wires with sufficient size to ensure voltage drop of less than 2%.

Motor torque may drop if operating at low frequencies and a long wire run between inverter and motor.

When more than one motor is connected to one inverter, total wiring length should be less than 100m. Do not use a 3-wire cable for long distances. Due to increased leakage capacitance between wires, over-current protective feature may operate or equipment connected to the output side may malfunction.

Please reduce the constants of F46 Carrier frequency to prevent the current leakage when the wiring between the inverter and the motor is longer.

Connect only recommended braking resistor between the P and PR terminals. **Never short P and PR terminals. Shorting terminals may cause internal damage to inverter.**

The main circuit of the inverter contains high frequency noise, and can hinder communication equipment near the inverter. To reduce noise, install RFI filters or line noise filters on the input side of the inverter.

Do not use power factor capacitor, surge suppressors, or RFI filters on the output side of the inverter. Doing so may damage these components.

Always insure the CHARGE LED lamp for the power terminal are OFF before wiring terminals. The charge capacitor may hold high-voltage even after the power is disconnected.

Use caution to prevent the possibility of personal injury.

Grounding

The inverter is a high switching device, and leakage current may flow. Ground the inverter to avoid electrical shock. Use caution to prevent the possibility of personal injury.

Connect only to the dedicated ground terminal on the inverter. Do not use the enclosure or a chassis screw for grounding.

Grounding wiring should be as thick as possible. Grounding wire should be as short as possible and should be connected to the ground point as near as possible to the inverter.

The correct grounding is essential when using the inverter. 220V class: less than 100 . 440V class: less than 10 .

The grounding of the inverter should be separate from the grounding of welder.

Please refer to the below grounding method when there are multiple inverters used.

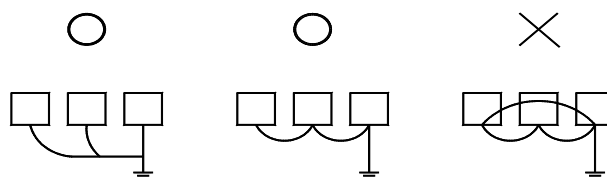

Motor Capacity	Grounding Wire Sizes, AWG (mm ²)	
	220V class	440V class
1.0 ~ 5.0 HP	12 (3.5)	14 (2)
7.5 ~ 10 HP	12 (3.5)	12 (3.5)

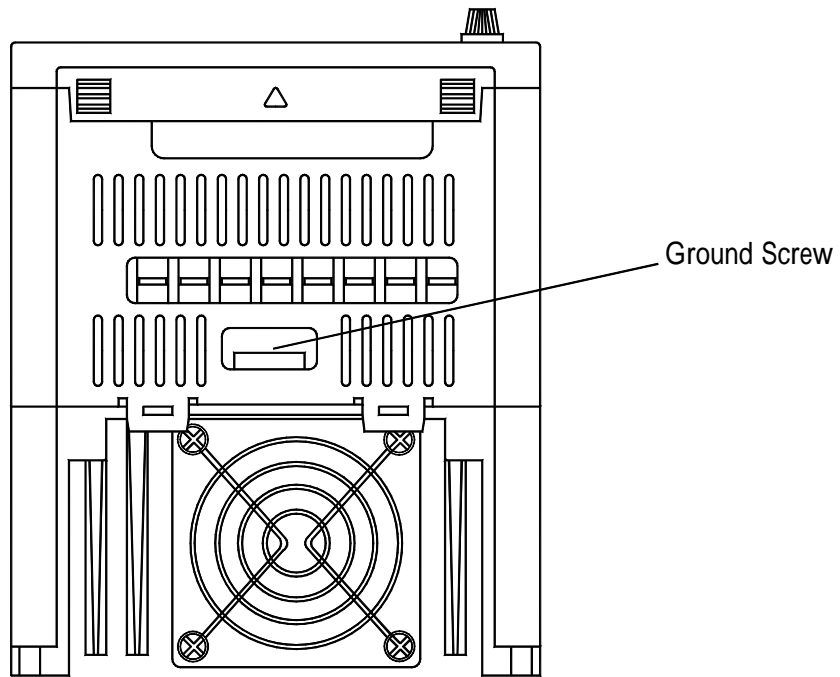

Wiring and Terminal Screw Sizes

Refer to the following table for wires and terminal specification of the inverter power input (R/L1, S/L2, T/L3) and output (U/T1, V/T2, W/T3).

Inverter Capacity		Terminal Screw Size	Screw Torque ¹ (Kgf-cm)/ lb-in	Terminals		Wire ²			
						mm ²		AWG	
				R/L1 S/L2 T/L3	U/T1 V/T2 W/T3	R/L1 S/L2 T/L3	U/T1 V/T2 W/T3	R/L1 S/L2 T/L3	U/T1 V/T2 W/T3
220V Class (Single-Phase)	1 ~ 3 HP	M 4.0	15/ 10	2 - 4	2 - 4	2	2	14	14
220V Class (3 - Phase)	1 HP	M 3.5	10/ 7	2 - 3.5	2 - 3.5	2	2	14	14
	2 ~ 3 HP	M 4.0	15/ 10	2 - 4	2 - 4	2	2	14	14
	5.0 HP	M 4.0	15/ 10	5.5 - 4	5.5 - 4	3.5	3.5	12	12
440V Class (3 - Phase)	7½ HP	M 4.0	25/ 16	5.5 - 4	5.5 - 4	5.5	5.5	10	10
	1.0 ~ 5.0 HP	M 4.0	15/ 10	2 - 4	2 - 4	2	2	14	14
	7½HP ~ 10HP	M 4.0	25/ 16	5.5 - 4	5.5 - 4	5.5	5.5	10	10

Power and Motor Connection

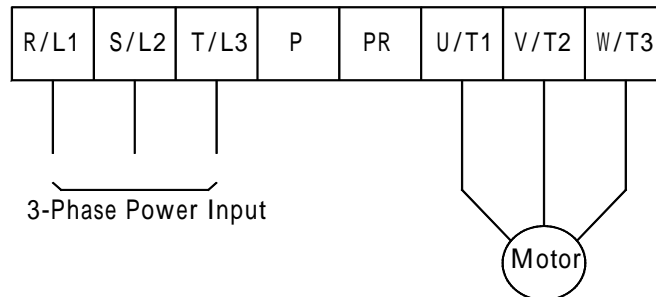

Power supply must be connected to the R/L1, S/L2, and T/L3 terminals.

Connecting it to the R/L1, S/L2, T/L3 terminals causes internal damages to the inverter.

Arranging the phase sequence is not necessary.

Motor should be connected to the U/T1, V/T2, and W/T3 terminals.

If the forward command (S1) is on, the motor should rotate clockwise when viewed from the load side of the motor. If the motor rotates in the reverse, switch the U/T1 and V/T2 terminals.

¹ Apply the rated torque to terminal screws. Loosen screws can cause short circuit and malfunction.

Tightening the screws too much can damage the terminals and cause short circuit and malfunction.

² Use copper wires with 600V, 75 ratings for wiring only.

Control Terminals

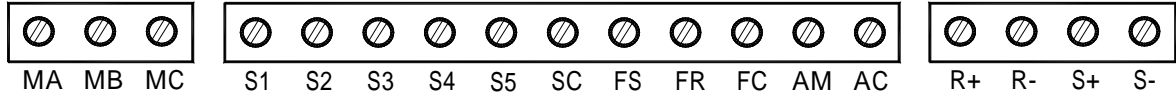

Type	Terminal	Name	Function (Signal Level)			
Main Circuit	Input	Sequence	S1	Multi-function input selection 1	Factory setting closed: FWD run open: REV run	Photo-coupler insulation, 24VDC, 8mA
			S2	Multi-function input selection 2	Factory setting closed: REV run open: FWD run	
			S3	Multi-function input selection 3	Factory setting: Fault reset	
			S4	Multi-function input selection 4	Factory setting: External fault (A contact)	
			S5	Multi-function input selection 5	Factory setting: Multi-step speed reference 1	
			SC	Multi-function input selection common	For control signal	
	Input	Frequency reference	FS	Power for frequency setting	+12V(permissible current 20mA max.)	
			FR	Master speed frequency reference	DC 0 ~ +10V(20K Ω), 4 ~ 20mA(250 Ω) 0 ~ 20mA(250 Ω) (1/1000 resolution)	
			FC	Frequency reference common	0V	
	Output	Multi-function output	MA	A contact output	Factory setting: Running	Contact capacity AC250V1A DC30V1A
			MB	B contact output		
			MC	Contact output common		
		AM		Analog monitor output	Factory setting: Output frequency 0 ~ +10V	DC0~+10V 2mA, 8bit resolution
		AC		Analog monitor common	0V	
	MODBUS Communication		R+	Communications input (+)	MODBUS communication run through RS-485 or RS-422 MODBUS protocol, 19.2KBPS max.	
R-			Communications input (-)			
S+			Communications output (+)			
S-			Communicaitons output (-)			

Control Circuit Wiring

Please insert the wiring of the control circuit to the wiring hole of the inverter base and adjust the switches according to different control signals.

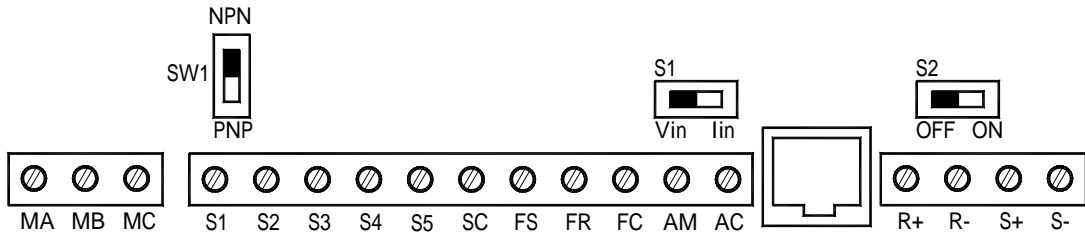

When connecting sequence inputs (S1~S5) with transistor, turn the rotary switch SW1 depending on the polarity (0V common: NPN side, 24V common: PNP side).

Factory setting: NPN side.

Refer to the communication impedance and the analog current input selection and analog voltage input selection for the connection of S1. Please refer to page 45.

S2 is the switch for RS485/RS422 communications impedance.

Sequence connection with NPN transistor (0V common)

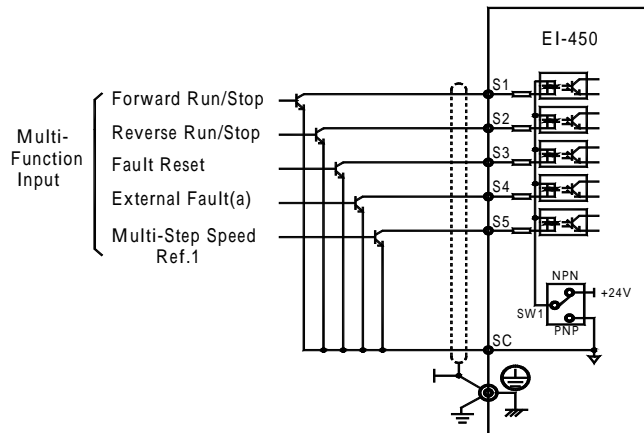

Sequence connection with PNP transistor (24V common)

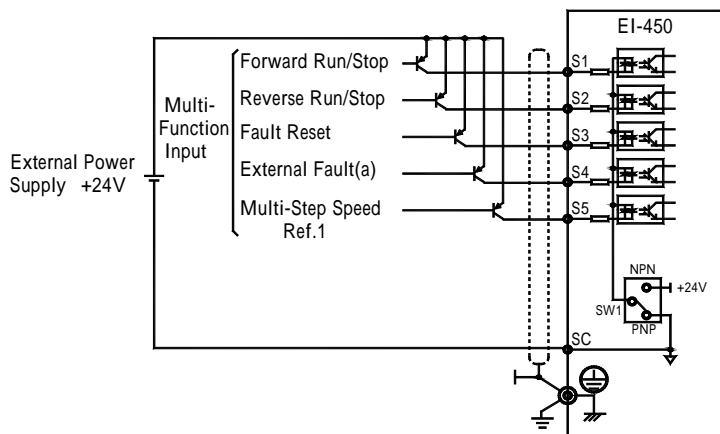

Wiring the control circuit terminals

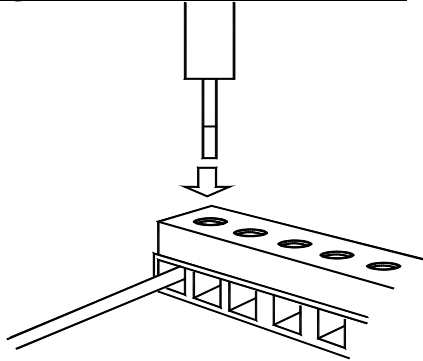

Screwdriver blade width

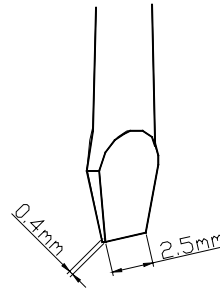

Insert the wire into the lower part of the terminal block and connect it tightly with a screwdriver.



Wire sheath strip length must be 5.5 mm

Wiring Inspection

After completing wiring, check the following:

- Wiring is proper.
- Screws are securely tightened.
- Bare wire in the terminal does not contact other terminals.
- Wire clippings or screws are not left in the unit.

NOTE: If the FWD/REV run command is given during the run command selection (F02=1) from the control circuit terminal, the motor will start automatically after the main circuit input power supply is turned ON.

CHAPTER 2 TEST RUN

Test Run

The inverter operates by setting the frequency (speed). There are three types of operation modes for EI-450 :

1. Run command from the simple operator RCUS-450 or digital operator RCU-450/RCU-450P.
2. Run command from the control circuit terminal.
3. Run command from communications (MODBUS communications).

Operation reference or frequency reference constants can be selected separately as shown below.

Name	Constants Description
Run command F02	=0 . Enables operator RUN, STOP (Initial setting) =1 . Enables control circuit terminal run/stop =2 . Enables communications (MODBUS communications)
Frequency reference selection F03	=0 . Enables simple or digital operator potentiometer (Initial setting) =1 . Enables frequency reference 1 (Constant F21) =2 . Enables voltage reference 0-10V of control circuit terminal =3 . Enables current reference 4-20mA of control circuit terminal =4 . Enables current reference 0-20mA of control circuit terminal =6 . Enables communications (MODBUS)

Test Run with Simple Operator RCUS-450

Operation steps	Status Indicator (LED)			
	DRIVE MODE	PRGM MODE	RUN	ALARM
1. Turn the potentiometer fully counter clockwise after turning the power ON.				
2. Press RUN key and turn the potentiometer the desired frequency value. ***If the volume is switched rapidly, the motor also accelerates or decelerates rapidly corresponding to the volume movement. Pay attention to load status and adjust the volume to the desired speed.***				

Note: ON OFF BLINKING

Test Run with Digital Operator RCU-450/RCU-450P

Operation steps	Operator display	Simple Run Indicator	Status Indicator
1. Turn the potentiometer fully counter clockwise after turning the power ON.	0.00	FREF ON	RUN ALARM BLINKING OFF
2. Press DSPL till F/R ON. Select FWD/REV run by using keys of and ***Never select REV when reverse run is prohibited.***	For or Rev	F/R ON	RUN ALARM BLINKING OFF
3. Press DSPL key till FREF ON and then press RUN key	0.00	FREF ON	RUN ALARM ON OFF
4. Turn the potentiometer the desired frequency value. ***If the volume is switched rapidly, the motor also accelerates or decelerates rapidly corresponding to the volume movement. Pay attention to load status and adjust the volume to the desired speed.***	0.00 ~ 60.00	FREF ON	RUN ALARM ON OFF

Operation Check Points

- Motor rotates smoothly.
- Motor rotates in the correct direction.
- Motor does not have abnormal vibration or noise.
- Acceleration and deceleration are smooth.
- Current matching the load flows.
- Status Indicators and Digital Operator Display are correct.



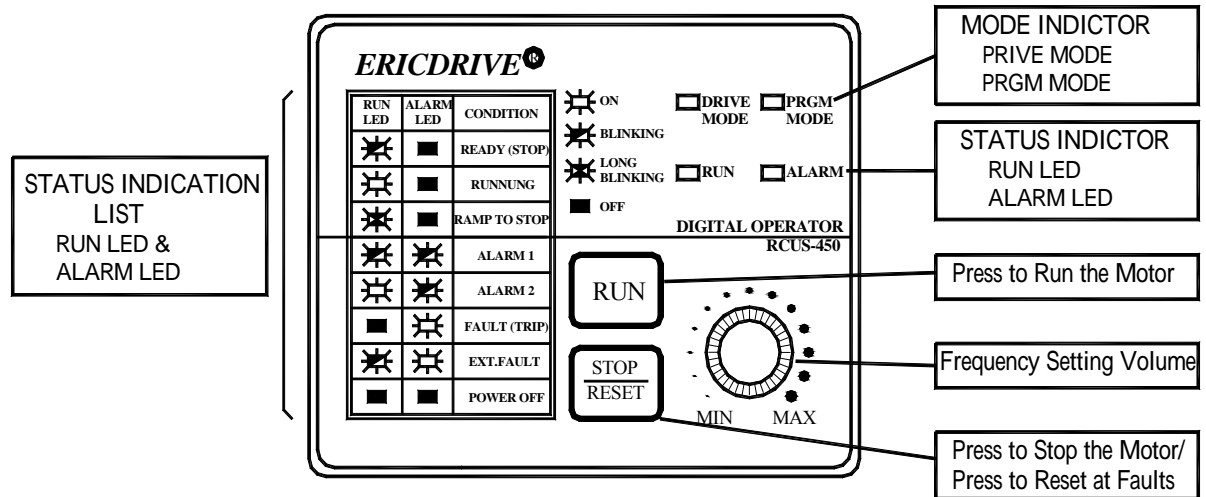













Simple Operator (RCUS-450) User Instruction







Mode Indicator



LED	Description
DRIVE MODE	When DRIVE MODE LED is ON, the inverter is in running mode and allows the inverter to run/stop and change output frequency.
PRGM MODE	<ul style="list-style-type: none"> When PRGM MODE LED is ON, the inverter is in constants modifying mode. <input type="button" value="RUN"/> key is disabled and <input type="button" value="STOP/RESET"/> key is enabled. When PRGM MODE LED is ON, it could be after using digital operator RCU-450 to modify the constants of the inverter, there is an immediate change for simple operator RCUS-450 without leaving PRGM mode. There are below two methods to change PRGM MODE to DRIVE MODE: <ol style="list-style-type: none"> POWER OFF EI-450 and then POWER ON it again. Return to digital operator RCU-450 and have the inverter leave PRGM MODE and use simple operator RCUS-450.

LED Display and User Instruction

RUN LED	ALARM LED	Inverter Status
		Operation ready (During stop).
		Normal operation.
		Ramp to stop.
		Inverter alarm. Fault contacts do not change the state. The inverter resets once the fault is removed.
		Inverter alarm. Fault contacts do not change the state. The inverter resets once the fault is removed.
		Inverter trips. Output is shut OFF and motor coast to a stop.
		Multi-function input S4 receives emergency stop signal.
		Low power supply or Control circuit is at fault or hardware circuit damaged.

Status Indicator Description	
LED 圖示	代表意義
	ON
	BLINKING
	LONG BLINKING
	OFF

The details of the Status Indicator at fault could be referred to “Chapter 6 FAULT DIAGNOSIS”

Note:  When running signal is in OFF condition, terminal S3 can reset the fault or press  on operator or turn OFF power supply and turn ON to clear the fault signal. But if the running signal is in ON condition, the fault can not be reset.

Digital Operator (RCU-450/RCU-450P) User Instruction

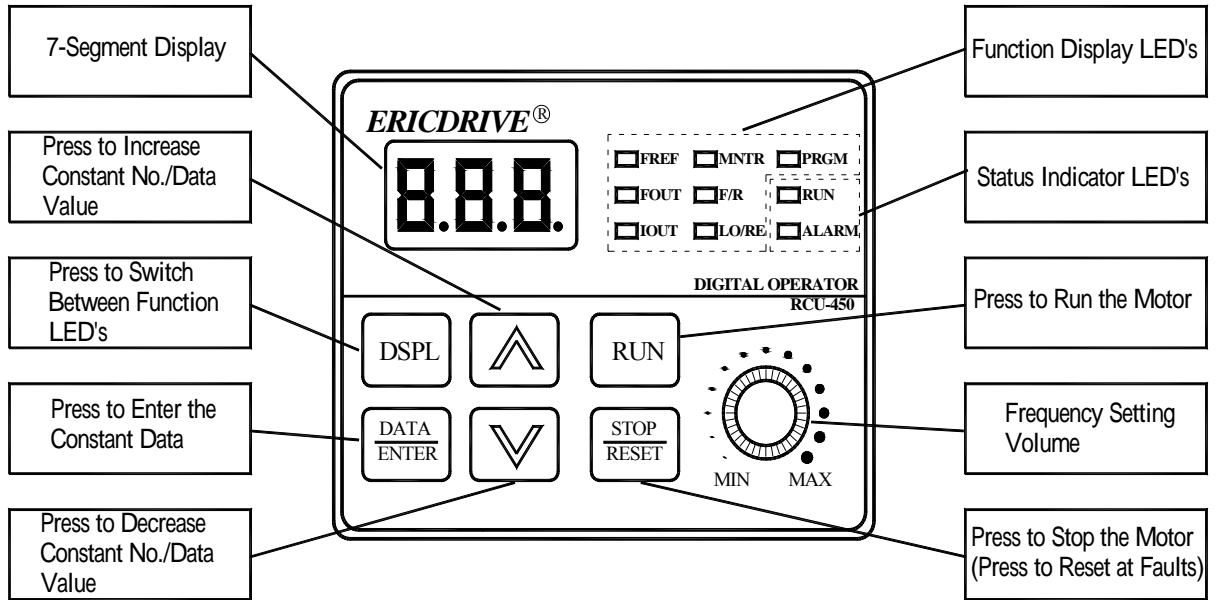

Run Mode Indicator

- FREF : Frequency reference setting/monitoring
- FOUT : Output frequency monitor
- IOUT : Output current monitor
- MNTR : Multi-function monitor. Use keys to select monitoring items in U-01~U-15
- F/R : Digital Operator RUN command FWD/REV selection. Use keys to select motor rotation direction when F/R is ON.

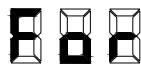

(Forward)

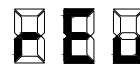

(Reverse)

- LO/RE : LOCAL/REMOTE selection. Use keys to select LOCAL/REMOTE

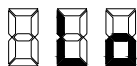



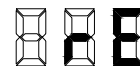

(Digital Operator RCU-450)



(External Terminal)

Constants Editing Mode Indicator:

PRGM :When it is ON, the inverter is constants editing mode. Use , ,  keys to monitor , set or change constants values.
Press  key to leave PRGM mode for Run mode.

Status Indicator:

There are RUN LED and ALARM LED on digital operator RCU-450/RCU-450P and their function is exactly the same as status indicators on RCUS-450. Please refer to page 25.

LED Display and User Instruction of Digital Operator RCU-450/RCU-450P:

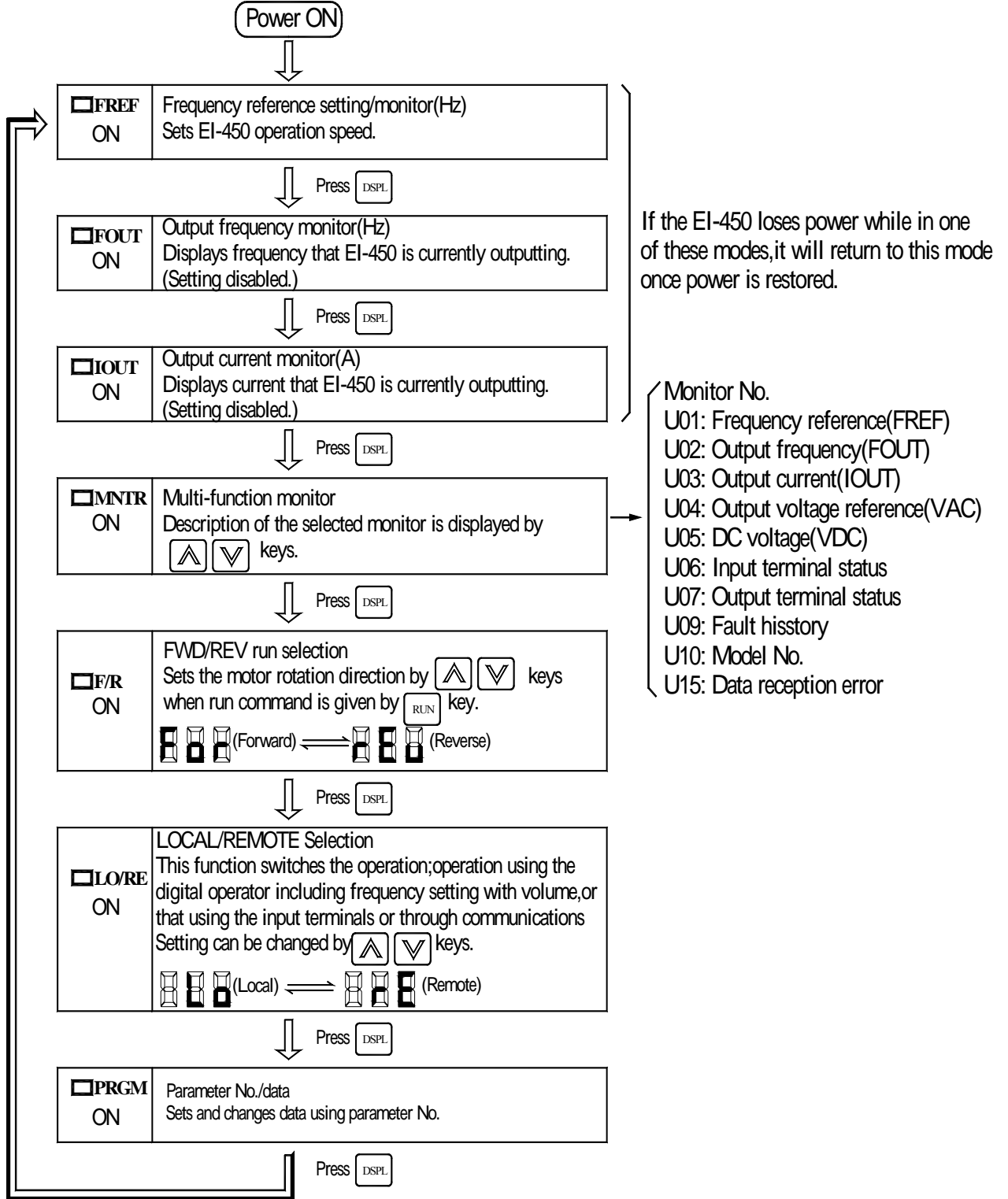

MNTR Multi-function Monitor

Press **DSPL** key. When MNTR is ON, data can be displayed by selecting monitor No.

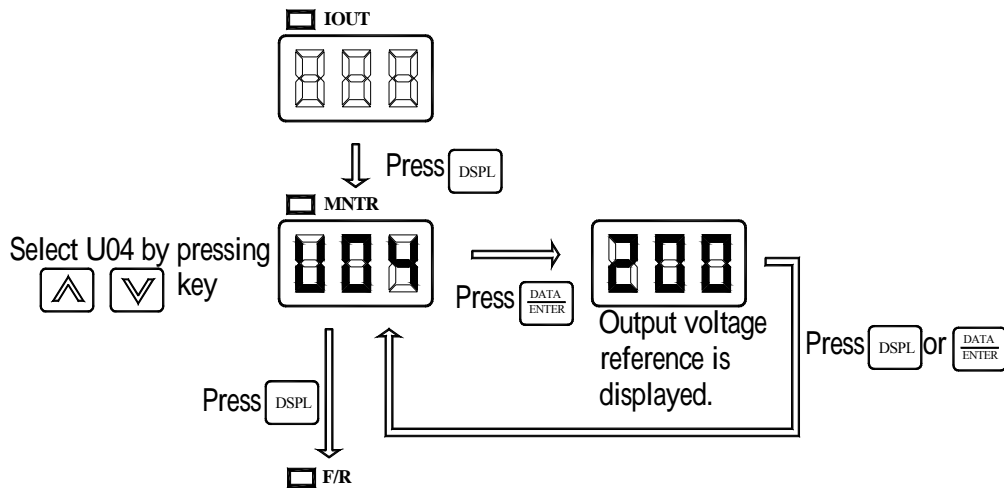

Monitoring

Following items can be monitored by U-constants:

Constant No.	Name	Unit	Description
U-01	Frequency reference (FREF)	HZ	Frequency reference can be monitored. (Same as FREF)
U-02	Output frequency (FOUT)	HZ	Output frequency can be monitored. (Same as FOUT)
U-03	Output current (IOUT)	A	Output current can be monitored (Same as IOUT)
U-04	Output voltage	VAC	Output voltage can be monitored.
U-05	DC voltage	VDC	Main circuit DC voltage can be monitored.
U-06	Input terminal status	–	Input terminal status of control circuit terminals can be monitored.(S1~S5)
U-07	Output terminal status	–	Output terminal status of control circuit terminals can be monitored.(MA)
U-09	Fault history	–	Newest fault history is displayed.
U-10	Model No.	–	Model No. can be checked.
U-15	Data reception error	–	Contents of MODBUS communication data reception error can be checked.

- U-09 can display newest fault history.
- Clear the fault history by setting F01=6 (fault history cleared) or F01=8 or 9.

Input/Output Terminal Status

Input terminal status:

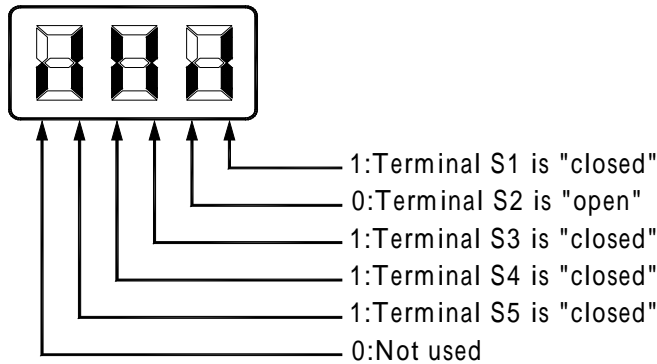

Output terminal status:

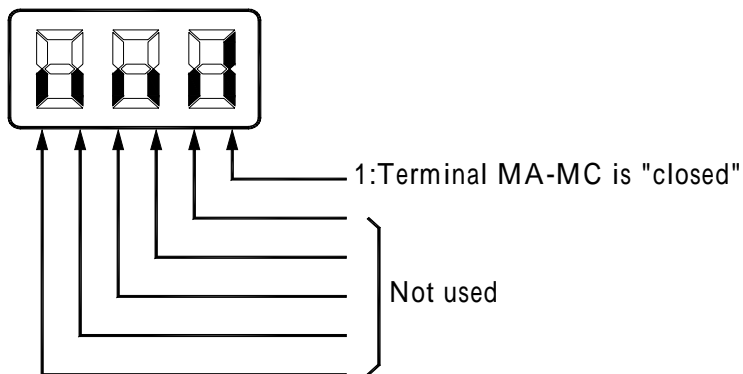

LOCAL/REMOTE Selection

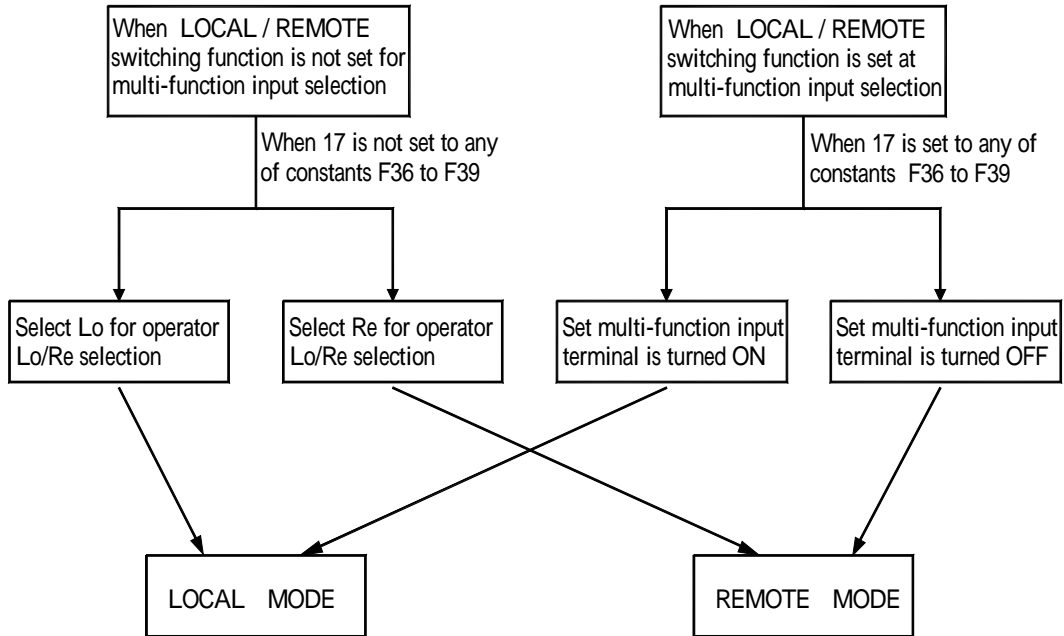

- LOCAL mode: Enables the digital operator RCU-450/RCU-450P for RUN/STOP commands and FWD/REV run commands. Frequency reference can be set by potentiometer or **FREF**.
- REMOTE mode: Enables the digital operator RCU-450/RCU-450P for RUN/STOP commands (F03) and FWD/REV run commands (F02) or for multi-function input terminal and communications mode.

Switching LOCAL/REMOTE Modes



Selecting Run/Stop Commands

Refer to LOCAL/REMOTE selection to select either LOCAL or REMOTE mode. Operation method (RUN / STOP commands, FWD / REV run commands) can be selected by the following method.

- **LOCAL Mode:**
When LO (local mode) is displayed on the digital operator RCU-450/RCU-450P (when is illuminated), or when the LOCAL / REMOTE changeover function is set as a multi-function input and the input terminal is turned ON, run operation is enabled by the RUN or STOP key. FWD/REV is selected by illuminating F/R and using  or  key to select FWD or REV.
- **REMOTE Mode:**
Select RE (remote mode). When the local / remote switching function is selected as multi-function input selection, turn OFF the input terminal to select remote mode. Select operation method by setting the constant F02:
F02 : = 0 . . . Enables the digital operator (RCU-450/RCU-450P)
 = 1 . . . Enables the multi-function input terminal
 = 2 . . . Enables communications (MODBUS)
Frequency reference: Setting the constant F03.

EI-450 Setting and Referring Constants

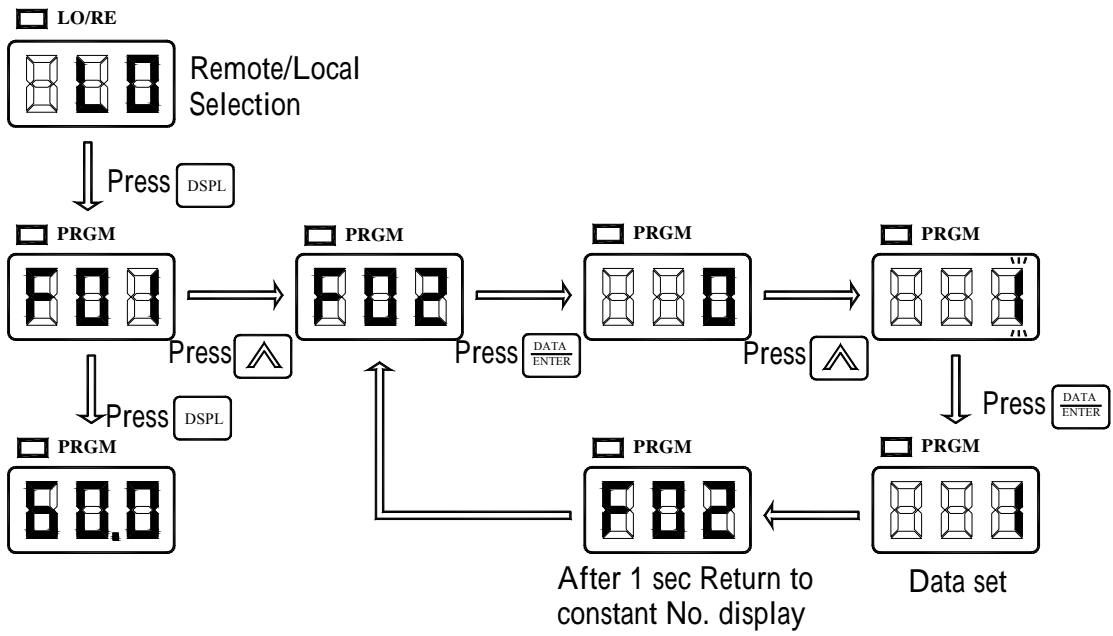

Simple Run Setting

Following is an example of the run setting: Condition request to have frequency 45.00HZ controlled by digital operator RCU-450/RCU-450P; acceleration time is 18 seconds; deceleration time is 3 seconds for forward/reverse setting. (F03=1)

Operation steps	Operator display	Simple Run Indicator		Status Indicator	
1. Turn ON the power supply.	0.0	FREF	ON	RUN ALARM	BLINKING OFF
2. Press DSPL key. When PRGM is ON, set F03 to 1	1	PRGM	ON	RUN ALARM	BLINKING OFF
3. Set the following constants. F16 =18.0 (acceleration time) F17 = 3.0 (deceleration time)	18.0 3.0	PRGM	ON	RUN ALARM	BLINKING OFF
4. Press DSPL key. When F/R is ON, select forward or reverse run by pressing up or down key. ***Examine the application. Never select REV when reverse run is prohibited.***	For or Rev	F/R	ON	RUN ALARM	BLINKING OFF
5. Press DSPL key. When FREF is ON, press up and down key to set the reference 45Hz.	45.0	FREF	ON	RUN ALARM	BLINKING OFF
6. Press DSPL key. When FOUT is ON, press RUN key to run the inverter.	0.0 > 45.0	FOUT	ON	RUN ALARM	ON OFF
7. Press STOP key to stop the inverter.	45.0 > 0.0	FOUT	ON	RUN DECEL ALARM	ON BLINKING OFF

CHAPTER 3 CONSTANTS LIST

No.	Register No. for Transmission	Name	Description	Initial Setting	Ref. Page
01	0301H	Constants write-in prohibit / initialize	0: Constant F001 set / read and constant F02 ~ F79 can be read. (FREF of the operator can be set.) 1: Functions (constants F01 ~ F79) can be set / read. 6: Clear fault history 8: 2 wire initialize 9: 3 wire initialize	1	43
02	0302H	Operation reference selection	0: Digital operator 1: Control circuit terminal 2: Communication	1	44
03	0303H	Frequency reference selection	0: Digital operator potentiometer 1: Frequency reference 1 (F21) 2: Control circuit terminal (voltage 0 ~ 10V) 3: Control circuit terminal (current 4 - 20 mA) 4: Control circuit terminal (current 0 - 20 mA) 5: Not used (setting error) 6: Serial communication (MODBUS)	0*4	44
04	0304H	Stopping method selection	0: Decel to stop 1: Coast to stop	0	46
05	0305H	REV run prohibit	0: Reverse run enabled 1: Reverser run disabled	0	47
06	0306H	Operation stop key selection	0: Stop key enabled 1: Stop key is enabled only when run command is selected to the digital operator.	0	47
07	0307H	Frequency reference selection in local mode	0: Frequency reference from digital operator pot 1: Frequency reference selection (F21)	0 (Note4)	47
08	0308H	Setting method selection for frequency reference	0: Frequency reference setting by the operator is enabled with the ENTER key input. 1: Frequency reference setting by the operator is not required the ENTER key input.	0	48

No.	Register No. for Transmission	Name	Description	Initial Setting	Ref. Page
09	0309H	Maximum output frequency	Setting unit: 0.1Hz (less than 100Hz) / 1Hz (100Hz or greater) Setting range: 50.0 ~ 400Hz	60.0Hz	48
10	030AH	Maximum voltage	Setting unit: 1V Setting range: 1 ~ 255V	230V (Note 1)	48
11	030BH	Maximum voltage output frequency	Setting unit: 0.1Hz (less than 100Hz) / 1Hz (100Hz or greater) Setting range: 0.2 ~ 400Hz	60.0Hz	48
12	030CH	Mid. output frequency	Setting unit: 0.1Hz (less than 100Hz) / 1Hz (100Hz or greater) Setting range: 0.1 ~ 399Hz	1.5Hz	48
13	030DH	Mid. output frequency voltage	Setting unit: 1V Setting range: 1 - 255V	12V (Note1)	48
14	030EH	Minimum output frequency	Setting unit: 0.1Hz Setting range: 0.1 ~ 10.0Hz	1.5Hz	48
15	030FH	Minimum output frequency voltage	Setting unit: 1V Setting range: 1 ~ 50V	12V (Note1)	48
16	0310H	Acceleration time 1	Setting unit: 0.1s (less than 100s) / 1s (100s or greater) Setting range: 0.0 ~ 999s	10.0s	51
17	0311H	Deceleration time 1	Setting unit: 0.1s (less than 100s) / 1s (100s or greater) Setting range: 0.0 ~ 999s	10.0s	51
18	0312H	Acceleration time 2	Setting unit: 0.1s (less than 100s) / 1s (100s or greater) Setting range: 0.0 ~ 999s	10.0s	51
19	0313H	Deceleration time 2	Setting unit: 0.1s (less than 100s) / 1s (100s or greater) Setting range: 0.0 ~ 999s	10.0s	51
20	0314H	S-curve accel / decel selection	0: No S-curves 1: 0.2s 2: 0.5s 3: 1.0s	0	51
21	0315H	Frequency reference 1 (Master speed frequency reference)	Setting unit: 0.1Hz (less than 100Hz) / 1Hz (100Hz or greater) Setting range: 0.0 ~ 400Hz	6.0Hz	53
22	0316H	Frequency reference 2	Setting unit: 0.1Hz (less than 100Hz) / 1Hz (100Hz or greater) Setting range: 0.0 ~ 400Hz	0.0Hz	53

No.	Register No. for Transmission	Name	Description	Initial Setting	Ref. Page
23	0317H	Frequency reference 3	Setting unit: 0.1Hz (less than 100Hz) / 1Hz (100Hz or greater) Setting range: 0.0 ~ 400Hz	0.0Hz	53
24	0318H	Frequency reference 4	Setting unit: 0.1Hz (less than 100Hz) / 1Hz (100Hz or greater) Setting range: 0.0 ~ 400Hz	0.0Hz	53
25	0319H	Frequency reference 5	Setting unit: 0.1Hz (less than 100Hz) / 1Hz (100Hz or greater) Setting range: 0.0 ~ 400Hz	0.0Hz	53
26	031AH	Frequency reference 6	Setting unit: 0.1Hz (less than 100Hz) / 1Hz (100Hz or greater) Setting range: 0.0 ~ 400Hz	0.0Hz	53
27	031BH	Frequency reference 7	Setting unit: 0.1Hz (less than 100Hz) / 1Hz (100Hz or greater) Setting range: 0.0 ~ 400Hz	0.0Hz	53
28	031CH	Frequency reference 8	Setting unit: 0.1Hz (less than 100Hz) / 1Hz (100Hz or greater) Setting range: 0.0 ~ 400Hz	0.0Hz	53
29	031DH	Jog frequency reference	Setting unit: 0.1Hz (less than 100Hz) / 1Hz (100Hz or greater) Setting range: 0.0 ~ 400Hz	6.00Hz	54
30	031EH	Frequency reference upper limit	Setting unit: 1% Setting range: 0 ~ 110%	100%	54
31	031FH	Frequency reference lower limit	Setting unit: 1% Setting range: 0 ~ 110%	0%	54
32	0320H	Motor rated current	Setting unit: 0.1A Setting range: 0 ~ 120% of inverter rated output current Note: if set to 0%, then electronic thermal motor overload is disable	(Note 2)	54
33	0321H	Electronic thermal motor protection	0: Standard motor application 1: Specialized motor application 2: No electronic motor overload protection	0	54
34	0322H	Constant selection at electronic thermal motor protection	Setting unit: 1min Setting range: 1 ~ 60min	8 min	54
35	0323H	Cooling fan operation selection	0: Controls the cooling fan OFF / ON 1: Operates when power is ON.	0	57

No.	Register No. for Transmission	Name	Description	Initial Setting	Ref. Page
36	0324H	Multi-function input selection 2	1: Not used 2: Reverse run reference (2 wire sequence) 3: External fault (A. contact input) 4: External fault (B. contact input) 5: Fault reset 6: Multi speed reference 1 8: Multi speed reference 2 7: Multi speed reference 3 9: Not used 10: Jog reference 11: Accel / decel time switching reference 12: External baseblock reference (A contact input) 13: External baseblock reference (B contact input) 14: Speed search command from Max. output frequency 15: Speed search command set frequency 16: Accel / decel hold 17: Local / remote switching 18: Communication / control circuit terminal switching 19: Emergency stop fault (A contact input) 20: Emergency stop alarm (A. contact input) 21: Emergency stop fault (B. contact input) 22: Emergency stop alarm (B contact input) 23~ 33: Unused	2	58
37	0325H	Multi-function input selection 3	0: Forward / reverse command (3 wire sequence) Others are the same as constant 36	5	58
38	0326H	Multi-function input selection 4	Same as constant 36	3	58

No.	Register No. for Transmission	Name	Description	Initial Setting	Ref. Page
39	0327H	Multi-function input selection 5	Same as constant F36 34: Up/down reference 35: Self-test (Note: valid power ON / OFF)	6	58
40	0328H	Multi-function output selection	0: Fault 1: During run 2: Frequency agree 3: During zero speed 4: Frequency detection (detection level or greater) 5: Frequency detection (detection level or less) 6: During over torque detection (A contact output) 7: During over torque detection (B contact output) 8: Not used 9: Not used 10: Minor fault (during warning display) 11: During baseblock 12: Run mode 13: Inverter ready 14: During fault retry 15: During UV 16: During reverse run 17: During speed search 18: Data output through communication	1	63
41	0329H	Analog frequency reference gain	Setting unit: 1% Setting range: 0 - 255%	100%	64
42	032AH	Analog frequency reference bias	Setting unit: 1% Setting range: -99 ~ 99%	0%	64
43	032BH	Analog frequency reference filter time constant	Setting unit: 0.01s Setting range: 0.00 ~ 2.00s (Note) When 0.00s is set, there is no filter	0.10s	64
44	032CH	Monitor item selection	0: Output frequency 1: Output current	0	65
45	032DH	Monitor gain	Setting unit: 0.01 Setting range: 0.01 ~ 2.00	1.00	66

No.	Register No. for Transmission	Name	Description	Initial Setting	Ref. Page
46	032EH	Carrier frequency	Set value: 1 ~ 4 carrier frequency = set value \times 2.5kHz Set value: Synchronous type of 7 ~ 9 lower limit 1kHz and upper limit 2.5 kHz	(Note 3)	66
47	032FH	Operation selection after momentary power loss	0: Operation does not continue. 1: Operation continues within momentary power ride through time 2: Operation always continues. (No UV1 fault detection)	0	68
48	0330H	Fault reset	Setting unit: time Setting range: 0 ~ 10 times	0 time	69
49	0331H	Jump frequency 1	Setting unit: 0.1Hz (less than 100Hz) / 1Hz (100Hz or greater) Setting range: 0.00 ~ 400Hz (Note) If 0.0Hz is set, jump frequency 1 is enabled.	0.0Hz	69
50	0332H	Jump frequency 2	Setting unit: 0.1Hz (less than 100Hz) / 1Hz (100Hz or greater) Setting range: 0.00 ~ 400Hz (Note) If 0.0Hz is set, jump frequency 2 is disabled.	0.0Hz	69
51	0333H	Jump frequency width	Setting unit: 0.1Hz Setting range: 0.0 ~ 25.5Hz (Note) If 0.0Hz is set, jump frequencies 1 ~ 2 are disabled.	0.0Hz	69
52	0334H	DC injection braking current	Setting unit: 1% Setting range: 0 ~ 100% (note) If 0% is set, it becomes baseblock status.	50%	69
53	0335H	DC injection braking time at stop	Setting unit: 0.1s Setting range: 0.0 ~ 25.5s (Note) If 0.0s is set, this function will not operate.	0.5s	69
54	0336H	DC injection braking time at start	Setting unit: 0.1s Setting range: 0.0 ~ 25.5s (Note) If 0.0s is set, this function will not operate.	0.0s	69

No.	Register No. for Transmission	Name	Description	Initial Setting	Ref. Page
55	0337H	Stall prevention (current limit) during decel	0: Stall prevention function is enabled during deceleration. 1: Stall prevention function is disabled during deceleration	0	70
56	0338H	Stall prevention (current limit) during accel	Setting unit: 1% Setting range: 30 ~ 200% (Note): If set at 200%, this function will not operate. (Note): For rated output range, the operator level is automatically reduced.	170%	71
57	0339H	Stall prevention (current limit) during running	Setting unit: 1% Setting range: 30 ~ 200% (Note): If set at 200%, this function will not operate.	160%	71
58	033AH	Frequency detection level	Setting unit: 0.1Hz (less than 100Hz) / 1Hz (100Hz or greater) Setting range: 0.00 ~ 400Hz	0.0Hz	72
59	033BH	Overtorque detection (OL3)	0: Overtorque detection disabled. 1: Detects only at speed agree, operation continues after detection. 2: Detects only at speed agree, output is shut down after detection. 3: Detects during run, operation continued after detection. 4: Detects during run, output is shut down after detection.	0	73
60	033CH	Overtorque detection Level (OL3)	Setting unit: 1% Setting range: 30 ~ 200%	160%	73
61	033DH	Overtorque detection Time (OL3)	Setting unit: 0.1s Setting range: 0.1 ~ 10.0s	0.1s	73
62	033EH	Memory selection of hold output frequency	0: Hold output frequency is not stored. 1: Hold output frequency is stored	0	74
63	033FH	Torque compensation gain	Setting unit: 0.1 Setting range: 0.0 ~ 2.5	1.0	74
64	0340H	Motor rated slip	Setting unit: 0.1Hz Setting range: 0.0 ~ 20.0Hz	(Note 2)	74
65	0341H	Motor no-load current	Setting unit: 1% Setting range: 0 ~ 99%	(Note 2)	74

No.	Register No. for Transmission	Name	Description	Initial Setting	Ref. Page
66	0342H	Slip compensation gain	Setting unit: 0.1 Setting range: 0.0 ~ 2.5	0.0	74
67	0343H	Slip compensation primary delay time	Setting unit: 0.1s Setting range: 0.0 ~ 25.5s	2.0s	74
68	0344H	Timeover detection selection	0: Timeover detection enabled. (Coast to stop) 1: Timeover detection enabled. (Deceleration stop by deceleration time 1) 2: Timeover detection enabled. (Deceleration stop by deceleration time 2) 3: Timeover detection enabled. (Operation continues, alarm displays) 4: Timeover detection disabled.	0	76
69	0345H	Setting unit selection of communications frequency reference/frequency monitor	0: 0.1Hz / 1 1: 0.01Hz / 1 2: 100% / 30000 3: 0.1% / 1	0	76
70	0346H	Slave address	Setting unit: 1 Setting range: 0 ~ 32	0	76
71	0347H	Baud rate selection	0: 2400 bps 1: 4800 bps 2: 9600 bps 3: 19200 bps	2	76
72	0348H	Parity selection	0: Even parity 1: Odd parity 2: No parity	0	76
73	0349H	Send waiting time	Setting unit: 1 = 1ms Setting range: 10 ~ 65 ms	10ms	76
74	034AH	RTS control	0: RTS control enabled 1: RTS control disabled	0	76
75	034BH	Carrier frequency at low speed	0: Disabled 1: Carrier frequency reduced to 2.5kHz when Fout = 5Hz and Iout = 110%	0	78

No.	Register No. for Transmission	Name	Description	Initial Setting	Ref. Page
76	034CH	Constants COPY function selection	rdy: Execution completed / execution command receive condition rEd: READ execute Cpy: COPY execute vFy: VRFY execute vA: kVA display Sno: Model No. display	rdy	78
77	034DH	Constants READ prohibit selection	0: READ prohibited. 1: READ allowed.	0	78
78	034EH	Fault history	The 1 newest event is displayed (Note) Setting is disabled.	–	–
79	034FH	Inverter model No.	Lower 3 digits of 450 numbers are displayed. (Note): Setting is disabled.	–	–

No. in refers to those constants which can be changed during operation.

*1 Upper limit of setting range and initial setting are doubled at 440V class.

*2 Changes depending on inverter capacity. Refer to the below.

*3 Changes depending on inverter capacity. The initial setting of carrier frequency can be referred to constant F46.

Initial Settings That Change with The Inverter Capacity

220V Class 3-phase/Single-phase

No.	Name	Unit	Initial Setting						
			1/4HP	1/2HP	1HP	2HP	3HP	5HP	7.5HP
-	Inverter capacity	HP							
F32	Inverter rated current	A	1.1	1.9	3.3	6.2	8.5	14.1	19.6
F64	Inverter rated slip	Hz	2.6	2.9	2.5	2.6	2.9	3.3	1.5
F65	Motor no-load current	%	73	62	55	45	35	32	26

440V Class 3-phase

No.	Name	Unit	Initial Setting					
			1HP	2HP	3HP	5HP	7.5HP	10HP
-	Inverter capacity	HP						
F32	Inverter rated current	A	1.6	3.1	4.2	7.0	9.8	13.3
F64	Inverter rated slip	Hz	2.6	2.5	3.0	3.2	1.5	1.3
F65	Motor no-load current	%	52	45	35	33	26	30

CHAPTER 4 PROGRAMMING FEATURES

F01: Constants write-in prohibit/initialize

Setting	Constant that can be set	Constant that can be referred (READ only)
0	F01	F01~F79
1	F01~F79	F01~F79
6	Fault history cleared	
7	Not used	
8	Initialize (2-wire sequence)	
9	Initialize (3-wire sequence) (F37=0)	

NOTE

Err appears on the LED display for one second and the set data returns to its initial values in the following cases:

- (1) The set values of multi-function input selection 2 to 5 (F36~F39) are the same.
- (2) If the following conditions are not satisfied in the V/F pattern setting:
 - Max. output frequency (F09) Max. voltage output frequency (F11)
 - > Mid. Output frequency (F12)
 - Min. output frequency (F14)
- (3) If the following conditions are not satisfied in the jump frequency setting:
 - Jump frequency 2 (F50) Jump Frequency 1 (F49)
- (4) If frequency reference lower limit (F31) Frequency reference upper limit (F30)
- (5) If motor rated current (F32) 120% of inverter rated current

F02: Operation reference selection

Select operation method by setting the constant F02.

- F02=0 Enables the digital operator RCU-450/RCU-450P/RCUS-450 (initial setting)
- =1 Enables the multi-function input terminal
- =2 Enables communications (MODBUS)

Example for using the multi-function input terminal as operation reference (two-wire sequence).

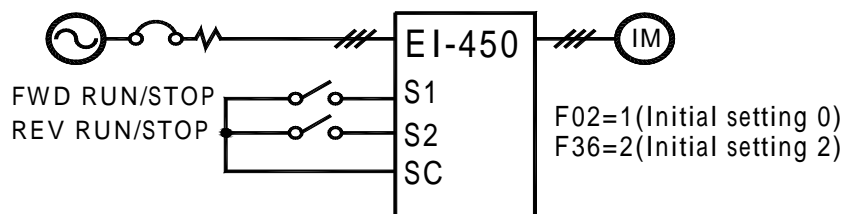

Operating (RUN/STOP Commands) by Communications

Setting constant F02 to 2 in REMOTE mode can give RUN/STOP commands by communication (MODBUS). For details, refer to page 76.

F03: Frequency reference selection

Select command method by constant F03.

- F03=0: Enables frequency reference setting by potentiometer on digital operator (RCU-450 or RCU-450P or RCUS-450). (Initial setting)
- =1: Frequency reference 1 (constant F21) is effective.
- =2: Voltage reference (0-10V) (FR terminal)
- =3: Current reference (4-20 mA) (FR terminal)
- =4: Current reference (0-20mA) (FR terminal)
- =6: MODBUS communications (R+, R-, S+, S- terminals)

F03=2: Example of frequency reference by voltage signal.

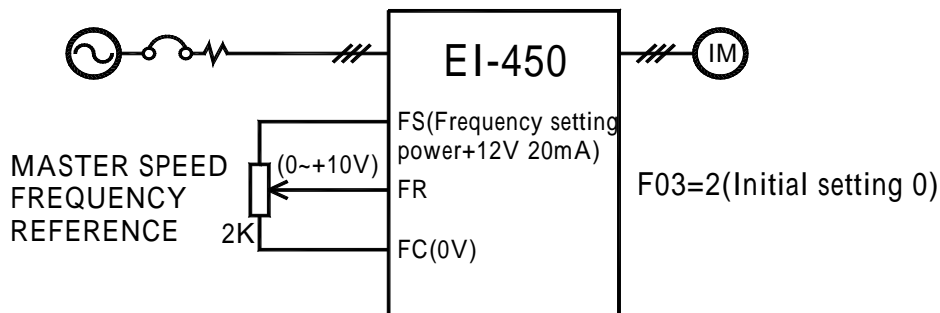

F03=3 (or 4)

When setting frequency by inputting current reference from the control circuit terminal FR, switch the DIP switch S1 to “I_{in}”.

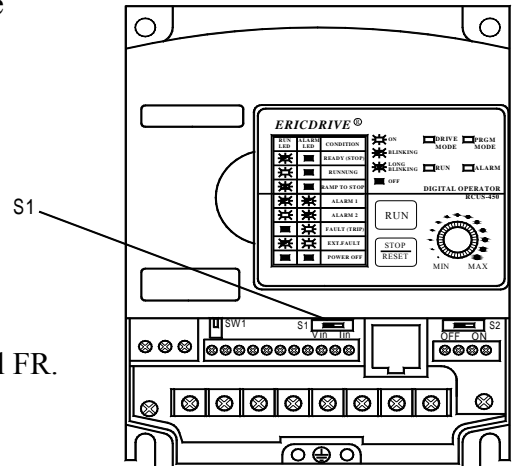
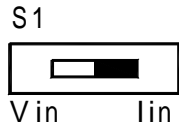

When the DIP switch S1 is switched to “I_{in}” side, never input voltage reference to control circuit terminal FR. The inverter might be damaged.

Select current reference method is as following:

- Current reference 4-20mA constant F03=3.
- Current reference 0-20mA constant F03=4.

The following two examples are two control method to control frequency reference by external current reference and they are adjusted by S1.

F02=0

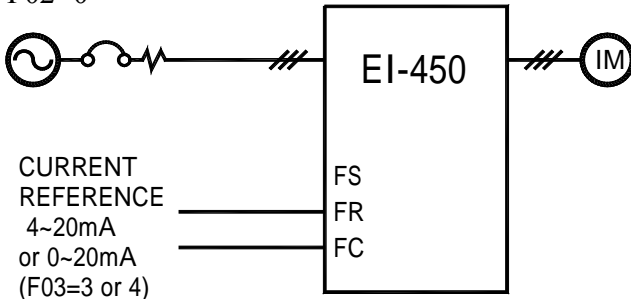

Example 1:

After switching DIP switch S1 to “I_{in}”, set constant F02 to 0, F03=3 (or 4). Press the digital operator keys to run or stop the inverter. Switch run and stop direction by setting F/R LED.

Set frequency by analog current signal constant F03 [0~100% (Max. frequency) /4~20mA or 0~20mA] .

F02=1

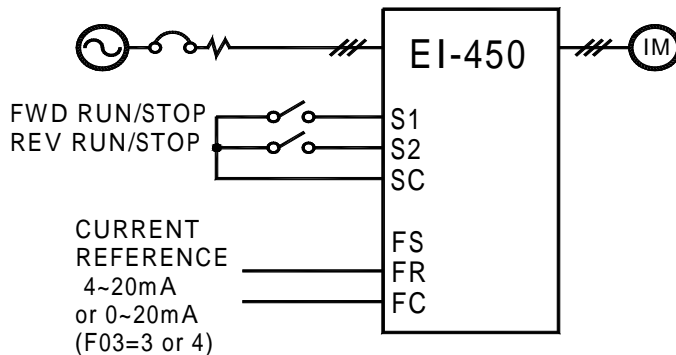

Example 2:

Set constant F02=1, F03=3 (or 4). Multi-function input terminal S1 is set to Forward run/Stop. Multi-function input terminal S2 is set to Reverse run/Stop (F36=2).

Set frequency by the analog current signal [0~100% (Max. frequency) /4~20mA or 0~20mA] .

Frequency reference gain (F41)/bias (F42) can be set even when current input is selected.

Communication Mode

Select RE for LO/RE selection. Turn OFF the multi-function input LOCA/REMOTE terminal and set F04 to 6. The frequency of the inverter is set by MODBUS setting frequency.

F04: Stopping method selection

Select the stopping method suitable for application.

F04 Setting	0 (Initial setting)	1
Stopping Method	Deceleration to stop	Coast to stop

F04=0 Deceleration to Stop

Example when accel/decel time 1 is selected.

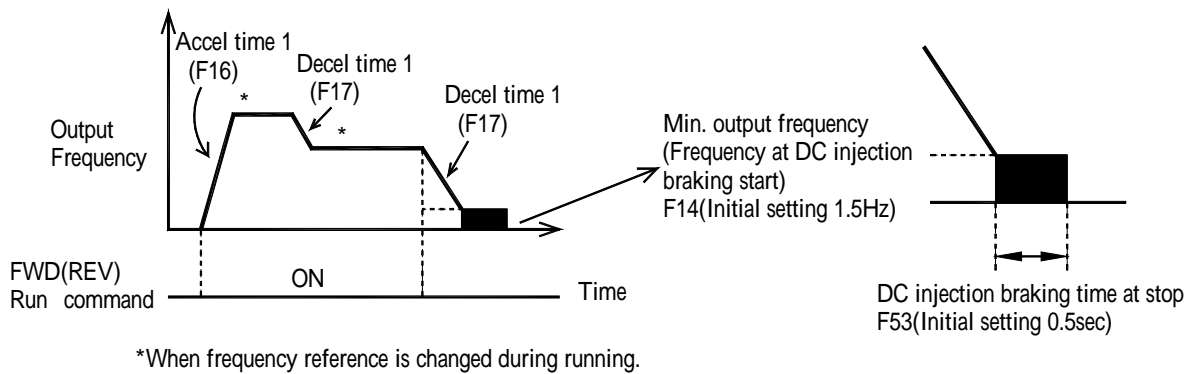

Upon termination of the FWD (REV) run command, the motor decelerates at the decel rate determined by the time set to deceleration time 1 and DC injection braking is applied immediately before stop. DC injection braking is also applied when the motor decelerates by setting frequency reference lower than min. output frequency with FWD (REV) run command ON. If the decel time is short or the load inertia is large, overvoltage (OV) fault may occur at deceleration. In this case, increase the decel time or install an optional braking resistor.

Braking torque: Without braking resistor: Approx. 20% torque of motor rating.
 With braking resistor: Approx. 150% torque of motor rating.

F04=1 Coast to Stop

Example when accel/decel time 1 is selected.

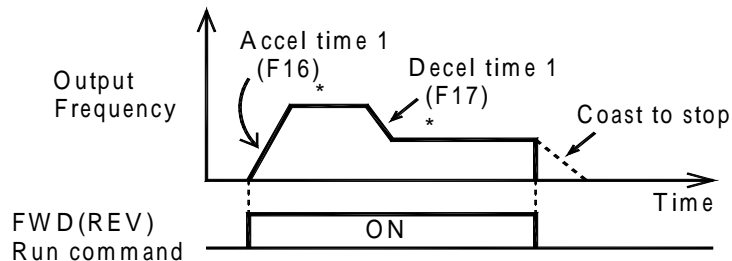

*When frequency reference is changed during running.

Upon removal of the FWD (REV)run command, the motor starts coasting.

F05: Reverse run prohibit

“ Reverse run prohibit” setting does not accept a reverse run command from the control circuit terminal or digital operator. This setting is used for applications where a reverse run command can cause problems.

F05 Setting	0 (Initial setting)	1
Content	Reverse run enabled	Reverse run disabled



F06: Operation stop key selection

Selects processing when STOP key is pressed during operation either from multi-function input terminal or communications.

F06 Setting	Description
0 (Initial setting)	STOP key effective when running either from multi-function input terminal or communications. When STOP key is pressed, the inverter stops according to setting of constant F04. At this time, the digital operator displays “ STP” alarm (blinking). This stop command is held in the inverter until both forward and reverse run commands are open, or until run command from communications becomes zero.
1	STOP key ineffective when running either from multi-function input terminals or communications.

F07: Frequency reference selection in LOCAL mode

F07=0(Initial setting): Enables the setting by potentiometer on digital operator.

=1 : Enables the digital setting by   keys on digital operator. The setting value is stored in constant F21 (Frequency reference 1).

F08: Setting method selection for frequency reference

When F07 is set to 1, Use   to set the frequency reference.

After setting the frequency reference, press  key.

*The initial setting of constant F08 is 0 and when setting the frequency reference,  key must be pressed.

F08=0: Enables frequency reference setting by  key.

=1: Disables frequency reference setting by  key.

F09: Maximum output frequency

F10: Maximum voltage

F11: Maximum voltage output frequency

F12: Mid. output frequency

F13: Mid. output frequency voltage

F14: Minimum output frequency

F15: Minimum output frequency voltage

No.	Name	Unit	Setting range	Initial setting
F09	Maximum output frequency	0.1 HZ	50.0 400.0HZ	60.0 HZ
F10	Maximum voltage	1V	0.1 255.0V (0.1 510.0V)	200.0V (400.0V)
F11	Maximum voltage output frequency	0.1 HZ	0.2 400.0HZ	60.0HZ
F12	Mid. Output frequency	0.1 HZ	0.1 399.9HZ	1.5HZ
F13	Mid. Output frequency voltage	1V	0.1 255.0V (0.1 510.0V)	12.0V (24.0V)
F14	Minimum output frequency	0.1 HZ	0.1 10.0HZ	1.5HZ
F15	Minimum output frequency voltage	1V	0.1 50.0V (0.1 100.0V)	12.0V (24.0V)

The value in () of F10, F13 and F15 is the setting of 440V class.

■ Selecting V/F Pattern

V/F setting is based on output frequency and output voltage. The initial setting is used for general motor and set each pattern when using a special motor (high-speed motor, etc.) or when requiring special torque adjustment of machine.

Be sure to satisfy the following condition.

$$F14 \quad F12 < F11 \quad F09$$

If $F14=F12$, the set value of F13 is disabled.

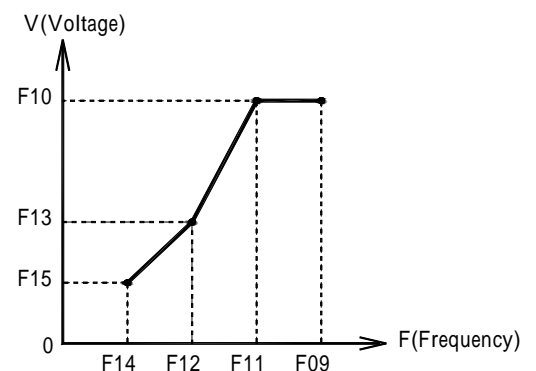

Typical Setting of V/F Pattern

- (1) Set the V/F pattern according to the application as described below.
- (2) For 440V class, the voltage values (F10, F13 and F15) should be doubled.
- (3) When running at a frequency exceeding 50Hz/60Hz, change the maximum output frequency (F09).

(1) For general-purpose applications

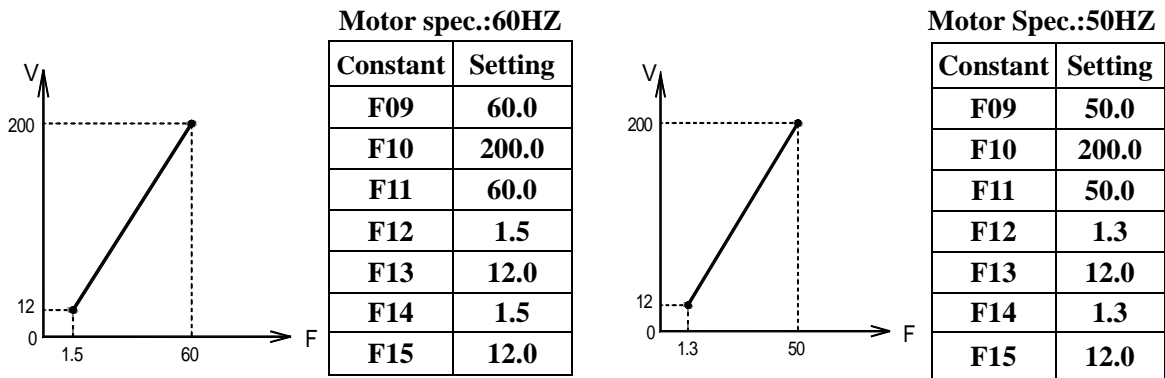

(2) For fans/pumps

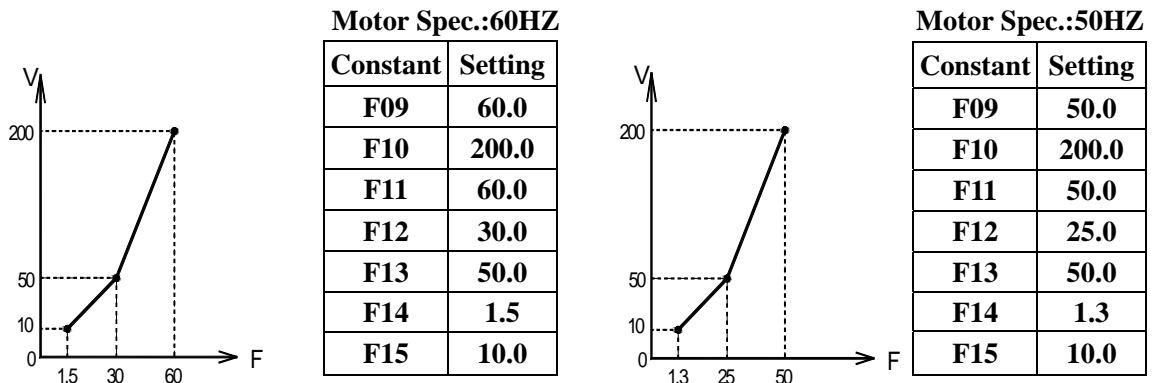

(3) For applications requiring high starting torque

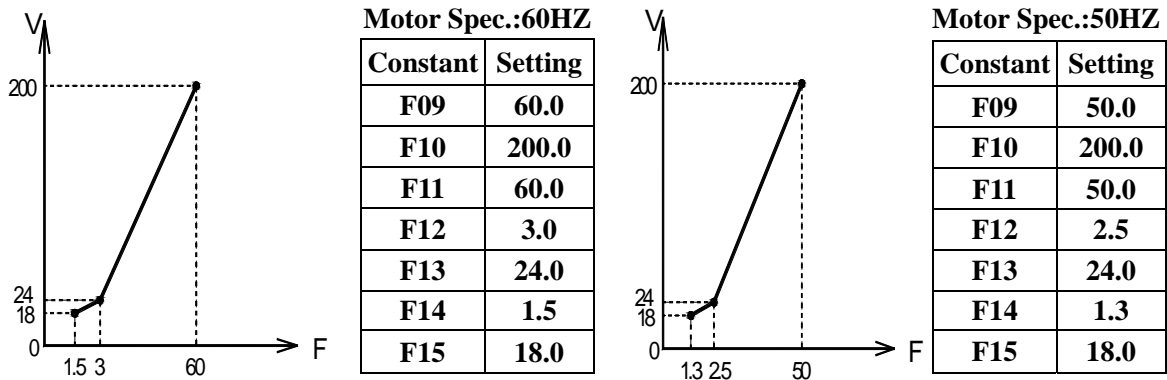

Increasing voltage of V/F pattern increase motor torque, but an excessive increase may cause :

- (1) motor overexcitation to damage inverter.
- (2) motor overheat or vibration so slowly increasing voltage and monitoring on motor current is suggested.

When operating with frequency larger than 60Hz/50Hz, change only maximum output frequency (F09).

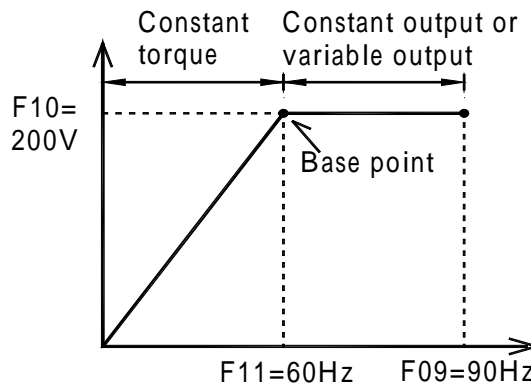

Full-range Automatic Torque Boost

Motor torque requirement changes according to load conditions. Full-range automatic torque boost adjusts voltage of V/F pattern according to the requirement. EI-450 automatically adjusts the voltage during constant-speed operation as well as acceleration. The required torque is calculated by the inverter and this ensures triples operation and energy-saving effects.

$$\boxed{\text{Output voltage}} \quad \boxed{\text{Torque compensation gain (F63)}} \times \boxed{\text{Required torque}}$$

Operation

Normally, no adjustment is necessary for torque compensation gain (F63). When the wiring distance between the inverter and the motor is long, or when the motor generates vibration, change the automatic torque boost gain. In these cases, set the V/F pattern (F09 to F15).
Initial setting: F63=10

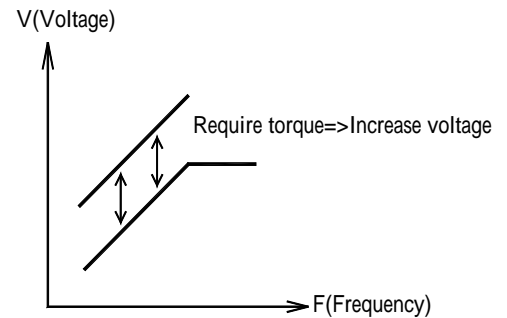

- F16: Acceleration time 1**
- F17: Deceleration time 1**
- F18: Acceleration time 2**
- F19: Deceleration time 2**
- F20: S-Curve accel/decel selection**

No.	Name	Units	Setting range	Initial setting
F16	Acceleration time 1	0.1s	0.0~999s	10.0s
F17	Deceleration time 1	(less than 100s)	0.0~999s	10.0s
F18	Acceleration time 2	1s	0.0~999s	10.0s
F19	Deceleration time 2	(more than 100s)	0.0~999s	10.0s

Using Two Accel/Decel Times

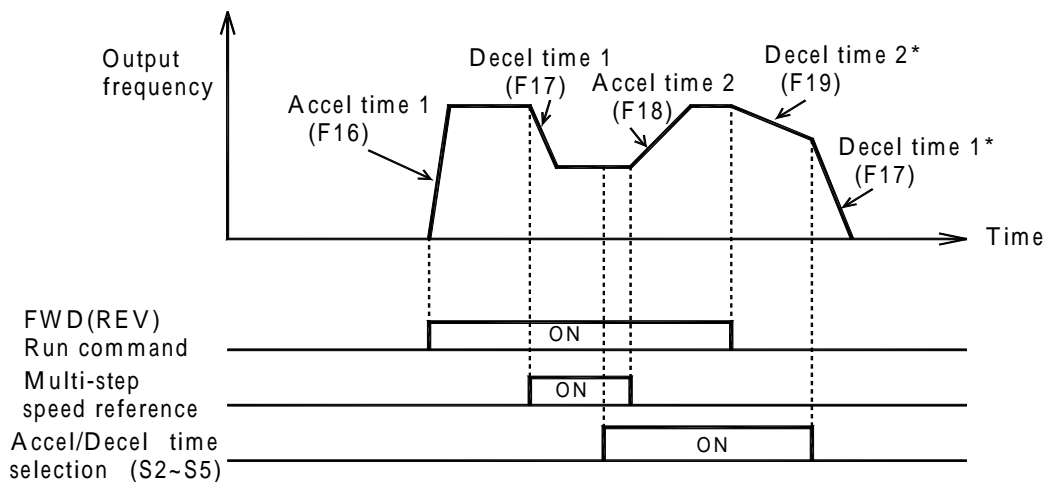

*When "deceleration to a stop" is selected (F04=0)

Set Multi-function input selection (F36~F39) to 11 (accel/decel time switching terminal). By the means of the combination of accel/decel time switching terminal 1 and accel/decel time switching terminal 2, accel/decel time is selected by turning ON/OFF the accel/decel time select (terminal S2 to S5).

AT OFF: F16 (accel time 1) are used.
 F17 (decel time 1)
 AT ON: F18 (accel time 2) are used.
 F19 (decel time 2)

- Accel time: Set the time needed for output frequency to reach 100% from 0%. (100% is the setting value of F09)
- Decel time: Set the time needed for output frequency to reach 0% from 100%.
 (Maximum output frequency F09=100%)

Soft-start Characteristics F20=0 (Initial Setting)

To prevent shock at machine start/stop, accel/decel can be performed in S-curve pattern.

Setting	S-curve selection
0	S-curve characteristic not provided
1	0.2s
2	0.5s
3	1.0s

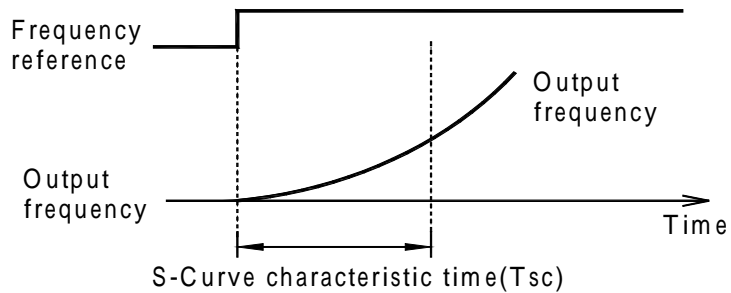

The following time chart shows FWD/REV run switching at deceleration to a stop.

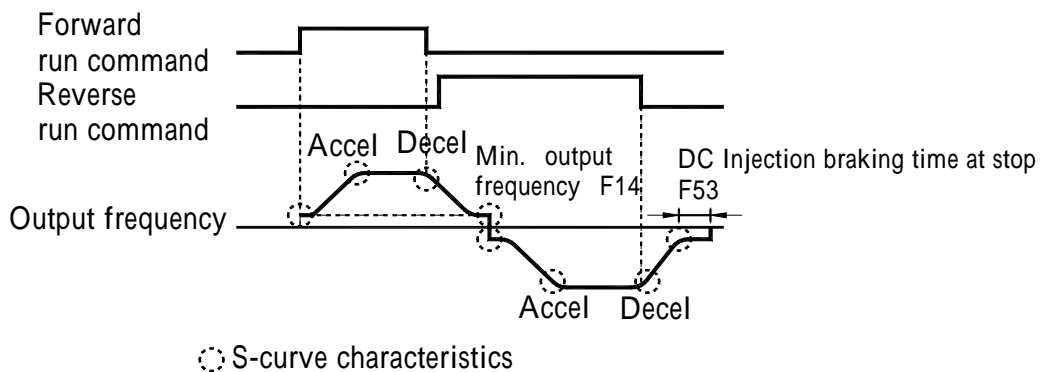

- F21: Frequency reference 1 (Master speed frequency reference)**
- F22: Frequency reference 2**
- F23: Frequency reference 3**
- F24: Frequency reference 4**
- F25: Frequency reference 5**
- F26: Frequency reference 6**
- F27: Frequency reference 7**
- F28: Frequency reference 8**

By combining frequency reference and input terminal function selections, up to 9 steps of speed can be set.

8-step speed change:

- F02=1 (Operation mode selection)
- F03=1 (Frequency reference selection)
- F21=25.0Hz (Frequency reference 1)
- F22=30.0Hz (Frequency reference 2)
- F23=35.0Hz (Frequency reference 3)
- F24=40.0Hz (Frequency reference 4)
- F25=45.0Hz (Frequency reference 5)
- F26=50.0Hz (Frequency reference 6)
- F27=55.0Hz (Frequency reference 7)
- F28=60.0Hz (Frequency reference 8)

- F36=2 (Multi-function contact input terminal S2)
- F37=6 (Multi-function contact input terminal S3)
- F38=7 (Multi-function contact input terminal S4)
- F39=8 (Multi-function contact input terminal S5)

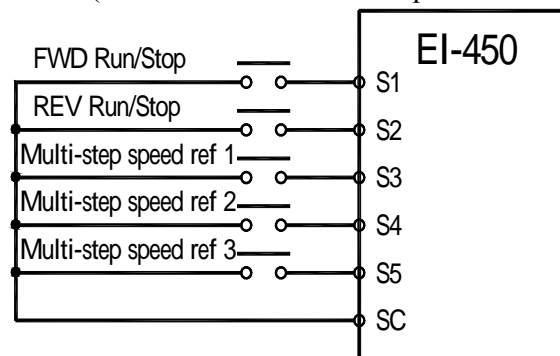

NOTE: When all multi-function reference inputs are OFF, frequency reference selected by constant F03 (frequency reference selection) becomes effective.

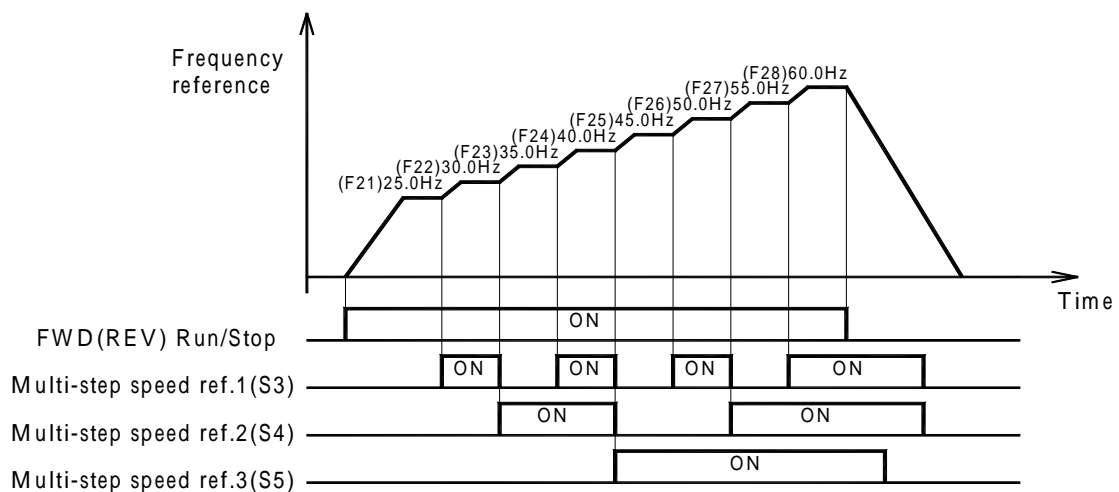

9-step speed change:

The setting is the same as 8-step speed change. Set F36=10 (Multi-function input terminal S2 as jog frequency). F29 jog frequency (0.0~400HZ) is used as frequency reference 9.

F29: Jog frequency reference (Frequency reference 9)

By inputting a jog command and then a forward (reverse) run command, operation is enabled at the jog frequency set in F29. When multi-step speed references 1, 2, 3 are input simultaneously with the jog command, the jog command has priority.

Constant No.	Name	Setting
F29	Jog frequency reference	Initial setting: 6.0HZ
F36 to F39	Jog reference	Set to "10" for any constant.

F30: Frequency reference upper limit

F31: Frequency reference lower limit

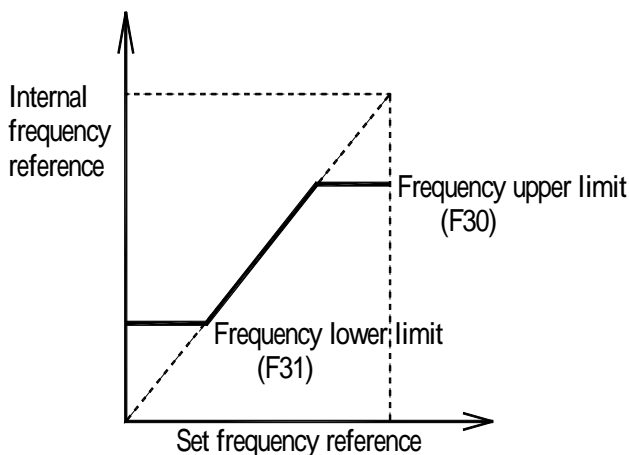

Frequency Reference Upper Limit (F30)

Sets the upper limit of the frequency reference in units of 1%.

(F09: Max. output frequency = 100%)

Frequency Reference Lower Limit (F31)

Sets the lower limit of the frequency reference in units of 1%.

(F09: Max. output frequency = 100%)

When operating at frequency reference 0, operation is continued at the frequency reference lower limit.

However, when frequency reference lower limit is set to less than the minimum output frequency (F14), operation is not performed

F32: Motor rated current

F33: Electronic thermal motor protection

F34: Constants selection at electronic thermal motor protection

Motor Overload Detection

EI-450 protects against motor overload with a built-in electronic thermal overload relay. Please do the proper setting as following.

Motor rated current(F32): Set to the rated current value shown on the motor nameplate.

Note: Setting to 0.0A disables the motor overload protective function.

Motor Overload Protection Selection (F33, F34)

F33 Setting	Electronic thermal characteristics
0 (Initial setting)	Applied to general-purpose motor
1	Applied to inverter motor
2	Electronic thermal overload protection not provided

Constants No.	Name	Unit	Setting range	Initial setting
F34	Electronic thermal motor protection	1 min	1~60 min	8 min

The electronic thermal overload function monitors motor temperature, based on inverter output current and time, to protect the motor from overheating. When electronic thermal overload relay is enabled, an “**OL1**” error occurs, shutting OFF the inverter output and preventing excessive overheating in the motor. When operating with one inverter connected to one motor, an external thermal relay is not needed. When operating several motors with one inverter, install a thermal relay on each motor.

General-purpose Motor and Inverter Motor

Induction motors are classified as general-purpose motors or inverter motors, based on their cooling capabilities. Therefore, the motor overload function operates differently between these two motor types.

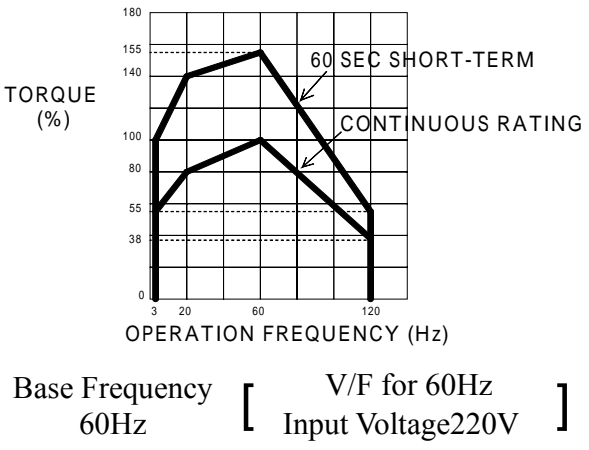
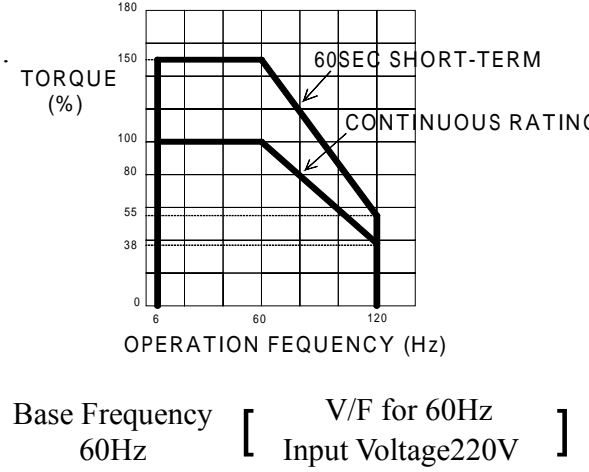
	Cooling effect	Torque characteristics	Electronic thermal overload
General-purpose Motor	Effective when operated at 50/60Hz from commercial power supply.	 <p>Base Frequency 60Hz [V/F for 60Hz Input Voltage 220V]</p> <p>For-low-speed operation, torque must be limited in order to stop motor temperature rise</p>	“ OL1” error (motor overload protection) occurs when continuously operated at 50/60Hz or less at 100% load.
Inverter Motor	Effective even when operated at low speed (approx. 6Hz).	 <p>Base Frequency 60Hz [V/F for 60Hz Input Voltage 220V]</p> <p>Use an inverter motor for continuous operation at low speed.</p>	Electronic thermal overload protection not activated even when continuously operated at 50/60Hz or less at 100% load.

F35: Cooling fan operation selection

In order to increase lifetime, the cooling fan can be set to operate only when inverter is running.

F35= 0 (Initial setting) : Operates only when inverter is running (Continues operation for 1 minute after inverter is stopped.)

= 1 : Operates with power ON.

F36: Multi-function input selection S2
F37: Multi-function input selection S3
F38: Multi-function input selection S4
F39: Multi-function input selection S5

- Multi-function input terminal S2 to S5 functions can be changed when necessary by setting constants F36 to F39 respectively. The same value cannot be set to different constant settings.
- The setting value and reference is as below.

Setting	Name	Description	Ref.
0	FWD/REV run command	Setting enabled only for F37 (terminal S3)	59
2	REV run (2-wire sequence selection)		59
3	External fault (a contact input)	Inverter stops by external fault signal input. Digital operator display is “EF ”.	—
4	External fault (b contact input)		—
5	Fault reset	Resets the fault. Fault reset not effective with the run signal ON.	—
6	Multi-step speed reference 1		53
7	Multi-step speed reference 2		53
8	Multi-step speed reference 3		53
10	JOG command		54
11	Accel/decel time select		51
12	External base block (a contact input)	Motor coast to a stop by this signal input.	—
13	External base block (b contact input)	Digital operator display is bb (blinking)	—
14	Search command from maximum frequency	Speed search reference signal	59
15	Search command from set frequency		59
16	Accel/decel hold command		60
17	LOCAL/REMOTE selection		60
18	Communication/ control circuit terminal selection		60
19	Emergency stop fault (a contact input)	Inverter stops by emergency stop signal input according to stopping method selection(F04). When frequency coasting to a stop (F04 is set to 1) method is selected, inverter coasts to a stop according to decel time setting 2 (F19). Digital operator display is “STP ” (lit at fault, blinking at alarm)	—
20	Emergency stop alarm (a contact input)		—
21	Emergency stop fault (b contact input)		—
22	Emergency stop alarm (b contact input)		—
34	UP/DOWN command	Setting enabled only for F39 (terminal S5)	61
35	Self-test	Setting enabled only for F39 (terminal S5)	62

- Initial Setting

No.	Terminal	Initial Setting	No.	Terminal	Initial Setting
F36	S2	2	F38	S4	3
F37	S3	5	F39	S5	6

Terminal Function at 3-wire Sequence Selection (F37=0)

When 0 is set at the terminal S3 (F37), terminal S1, S2 and S3 become the following command.

- S1: Run command
- S2: Stop command
- S3: FWD/REV run command

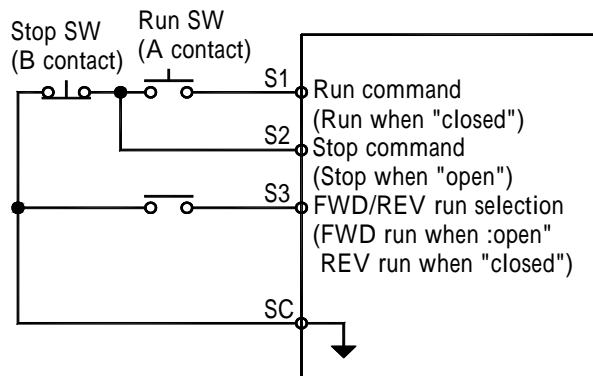

Restarts A Coasting Motor without Stopping Speed Search Command (F36~F39=14 or 15)

After inputting restarting speed search command in a coasting motor, inverter will stop output for a while (Min. Base Block time), then it will start to execute speed search.

- Set multi-function input terminal (F36~F39) to
- 14 (search command from “maximum output frequency”)
- 15 (search command from “set frequency”)

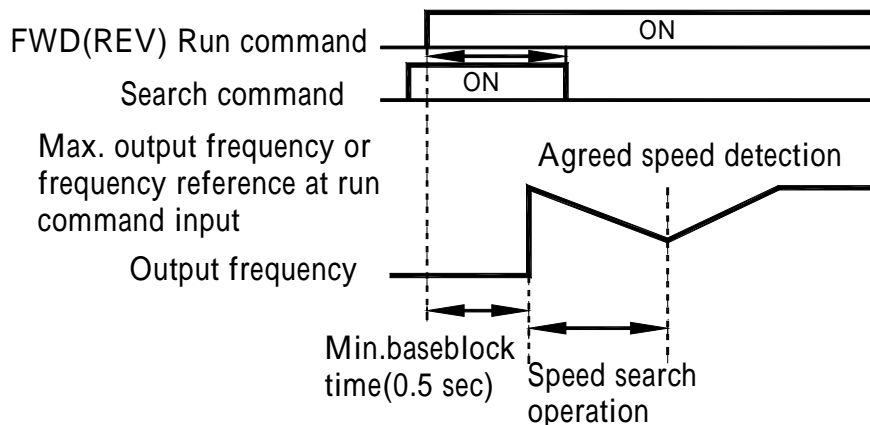

Holding Accel/Decel Temporarily (F36~F39=16)

When the stop command is input during accel/decel prohibition command input, accel/decel hold is released and operation ramps to stop.

Set multi-function input selection (F36to F39) to 16 (accel/decel prohibit).

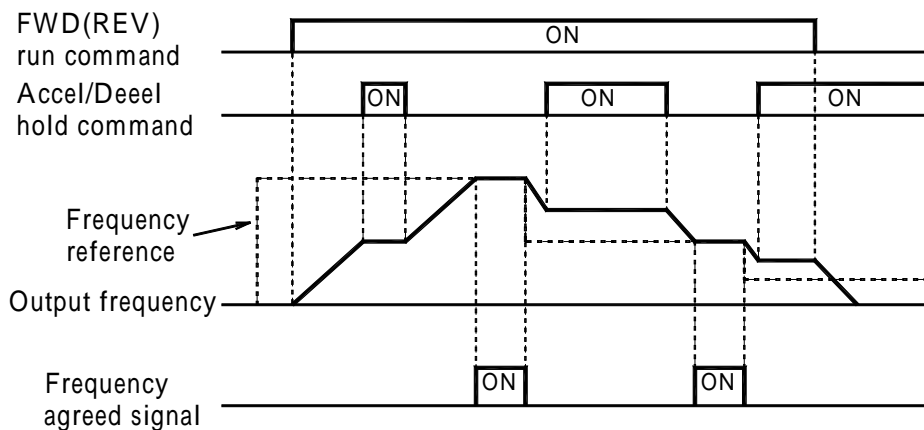

- * When the FWD (REV) run command is input along with the accel/decel hold command, the motor does not operate. However, when frequency reference lower limit (F31) is set greater than or equal to min. output frequency (F14), the motor operates at frequency reference lower limit.

LOCAL/REMOTE Selection (F50~F56=17)

Select operation reference either by the digital operator or by multi-function input terminals. LOCAL/REMOTE select is available only during stop.

Open: Run according to the setting of run command selection (F02) or frequency reference selection (F03).

Closed: Run by frequency reference and run command from the digital operator.

(Example) Set F02 = 1, F03 = 2, F07 = 0.

Open: Run by frequency reference from multi-function input (terminal FR, PS) and run command from multi-function input terminals S1 to S5.

Closed: Run by potentiometer frequency reference and run command from the digital operator.

Communication/Multi-function Input Terminal Selection Input (F50~F56=18)

Operation can be changed from communication command, or from multifunction input terminal or digital operator command.

Run command from communication and frequency reference are effective when multi-function input terminal for this setting is "Closed."

Run command in LOCAL/REMOTE mode and frequency reference are effective when "Open."

UP/DOWN Command (F39=34)

With the FWD (REV) run command entered, accel/decel is enabled by inputting the UP or DOWN signals to multi-function input terminals S4 and S5 without changing the frequency reference, so that operation can be performed at the desired speed.

When UP/DOWN commands are specified by F39, any function set to F38 becomes disabled; terminal S4 becomes an input terminal for the UP command and terminal S5 for the DOWN command.

Multi-function input terminal S4 (UP command)	Closed	Open	Open	Closed
Multi-function input terminal S5 (DOWN command)	Open	Closed	Open	Closed
Operation status	Accel	Decel	Hold	Hold

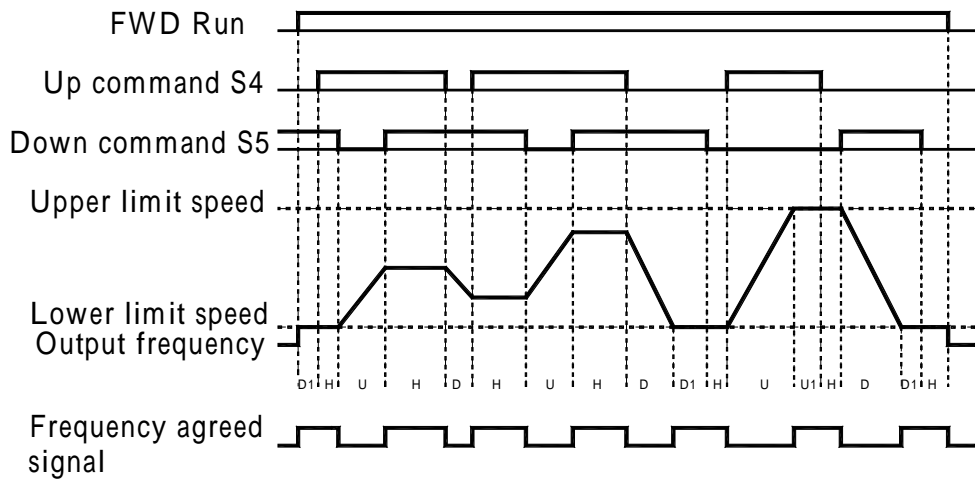

U=UP(acceleration)status
D=DOWN(deceleration)status
H=HOLD(constant speed)status
U1=UP status,clamping at upper limit speed
D1=DOWN status,clamping at lower limit speed

Notes :

- When UP/DOWN command is selected, the upper limit speed is set.
Upper limit speed = Maximum output frequency (F09)
✗ Frequency reference upper limit F30)/100
- Lower limit value is either minimum output frequency (F14) or frequency reference lower limit (F31) (whichever is larger.)
- When the FWD (REV) run command is input, operation starts at the lower limit speed without an UP/DOWN command.
- If the jog command is input while running by the UP/DOWN command, the jog command has priority.
- Multi-step speed reference 1 to 3 is not effective when UP/DOWN command is selected. Multi-step speed reference is effective during running in hold status.
- When "1" is set for HOLD output frequency memory selection (F62), output frequency can be recorded during HOLD.

F62 Setting	Description
0 (Initial setting)	Output frequency is not recorded during HOLD.
1	When HOLD status is continued for 5 seconds or longer, the output frequency during HOLD is recorded and the inverter restarts at the recorded frequency.

Communication Self Test (F39=35):

EI-450 is provided with a function to perform self-diagnosis for operation check of the serial communication I/F circuit. This function is called self-test. In the self-test, connect the sending terminal with the receiving terminal in the communication section. It assures if the data received by EI-450 is not being changed. It also checks if the data can be received normally.

Carry out the self-test in the following procedure.

1. Turn ON the EI-450 power supply. Set constant F39 to 35 (self-test).
2. Turn OFF the EI-450 power supply.
3. Make the following wiring with the power supply turned OFF.
4. Turn ON the EI-450 power supply.

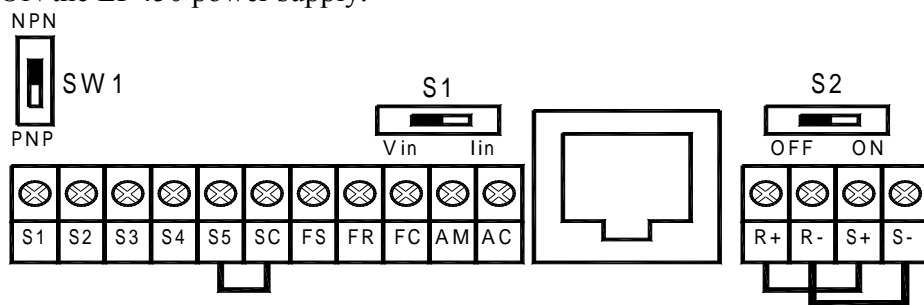

Normal operation: Operator displays frequency reference value.

Faulty operation: Operator displays “CE” fault; signal is turned “ON” and inverter ready.
Signal is turned OFF

F40: Multi-function output selection

Using Output Signal (F40)

Multi-function output terminal MA, MB functions can be changed by setting constants F40.

- Terminal MA, MB functions : Set to F40

Setting	Name	Description	Ref.
0	Fault	Closed when inverter fault occurs.	—
1	In operation	Closed when either FWD/REV command is input or voltage is output from the inverter.	—
2	Agreed frequency	Closed when setting frequency agrees with inverter output frequency.	64
3	Zero speed	Closed when inverter output frequency is less than minimum output frequency.	—
4	Frequency detection 1	Output frequency \geq frequency detection level (F58)	72
5	Frequency detection 2	Output frequency \leq frequency detection level (F58)	72
6	Overtorque detection (a contact output)	—	73
7	Overtorque detection (b contact output)	—	73
10	Minor fault(alarm)	Closed when the alarm is indicated.	—
11	Base blocked	Closed when the inverter output is shut off.	—
12	LOCAL operation mode	Closed when “LOCAL” is selected by LOCAL/REMOTE selection.	—
13	Inverter operation ready	Closed when inverter fault is not detected, and operation is ready.	—
14	Fault restart	Closed during fault retry	—
15	In UV	Closed when undervoltage is detected.	—
16	In reverse run	Closed during reverse run.	—
17	In speed search	Closed when inverter conducts speed search.	—
18	Data output from communication	Operates multi-function output terminal independently from inverter operation by MODBUS communication.	76

● **Initial Setting of Multi-Function Output Terminal**

Constants No.	Terminal	Initial setting
F40	MA, MB	1 (Inverter Run)

Frequency Agreed Signal (F40=2)

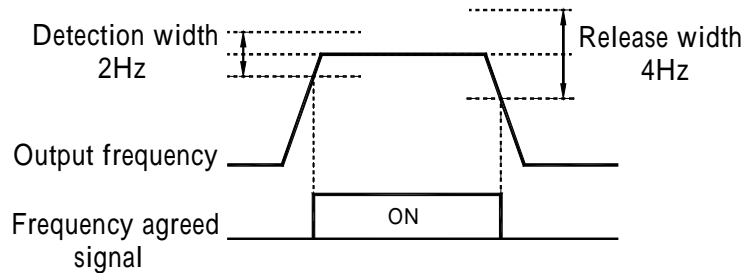

F41: Analog frequency reference gain
F42: Analog frequency reference bias
F43: Analog frequency reference filter time constant

Adjusting Speed Setting Signal

The relationship between the analog input signal and internal (terminal “FR”) frequency reference can be set by parameters F41 and F42.

Frequency reference gain (F41)

The max. frequency reference (F09) provided when analog input is max. can be set in units of 1%. (Max. output frequency F09=100%)

Factory setting: 100%

Frequency reference bias (F42)

The frequency reference provided when analog input is 0V (4mA or 0mA) can be set in units of 1%. (Max. output frequency F09=100%)

Factory setting: 0%

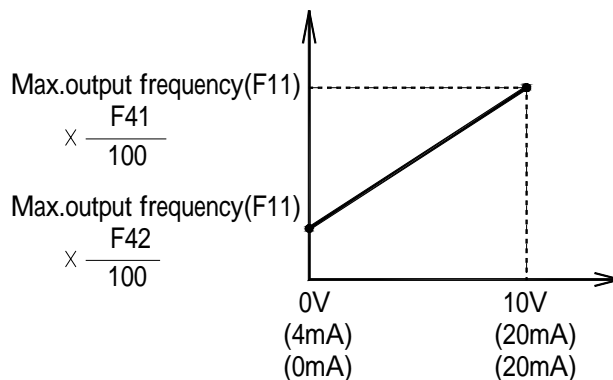

Example Setting:

(1) To operate the inverter with frequency reference of 0% to 100% at 0 to 5V input.

Gain F41 = 200%
Bias F42 = 0%

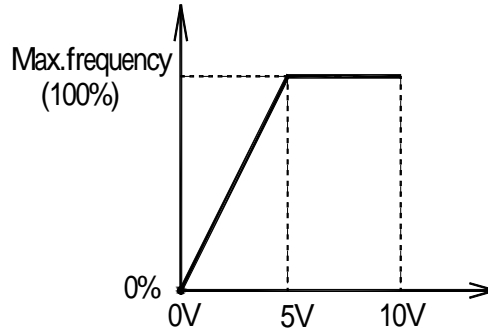

(2) To operate the inverter with frequency reference of 50% to 100% at 0 to 10V input.

Gain F41 = 100%
Bias F42 = 50%

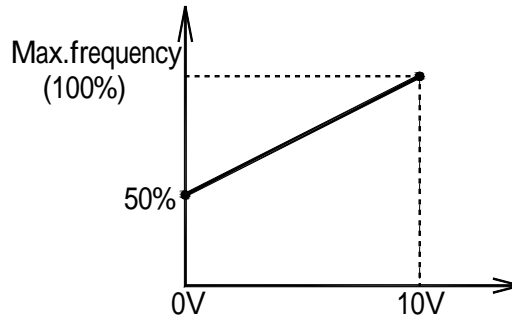

F44: Monitor item selection

Using Frequency Meter or Ammeter

Selects to output either output frequency or output current to analog output terminals AM-AC for monitoring.

F44 setting	Description
0 (Initial setting)	Output frequency
1	Output current

In initial setting, analog voltage of approx. 10V is output when output frequency (output current) is 100%.

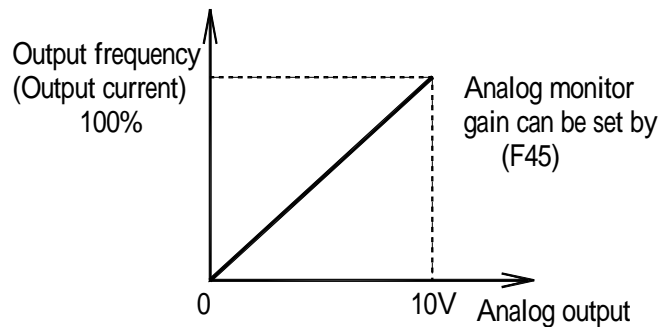
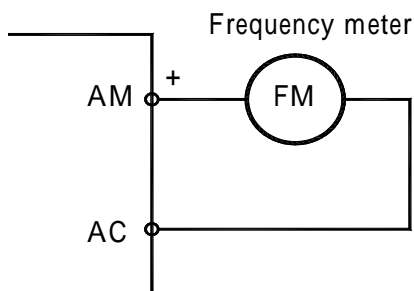

F45: Monitor gain

Calibrating Frequency Meter or Ammeter

Used to adjust analog output gain

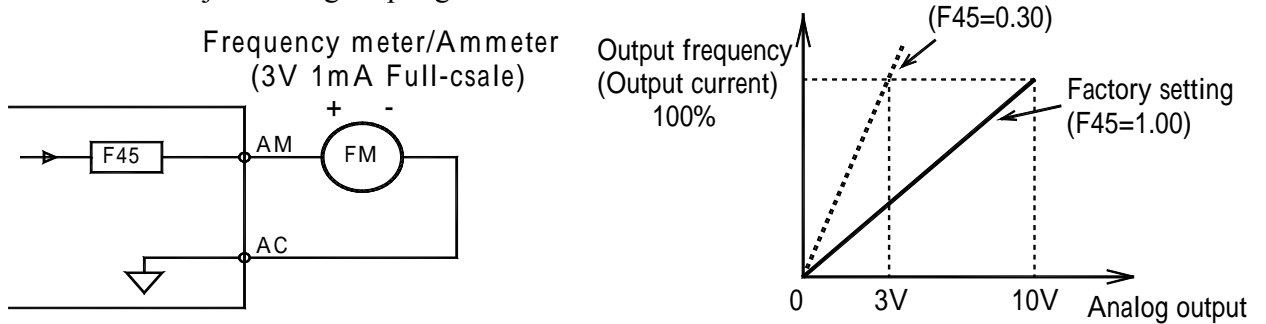

Example: Set the analog output voltage at 100% of output frequency (output current).
 Frequency meter displays 0 to 60Hz at 0 to 3V. $10 \times F45 \text{ setting } (0.30) = 3V$.

F46: Carrier frequency

Set inverter output transistor switching frequency (carrier frequency F46).

F46 Setting	Carrier frequency	Metallic noise from motor	Noise current leakage
7	12 f _{out} (HZ)	Higher	Smaller
8	24 f _{out} (HZ)		
9	36 f _{out} (HZ)		
1	2.5 (kHz)	Not audible	Larger
2	5.0 (kHz)		
3	7.5 (kHz)		
4	10.0 (kHz)		

Setting values 7, 8, or 9 multiplies output frequency according to output frequency value.

F46=7

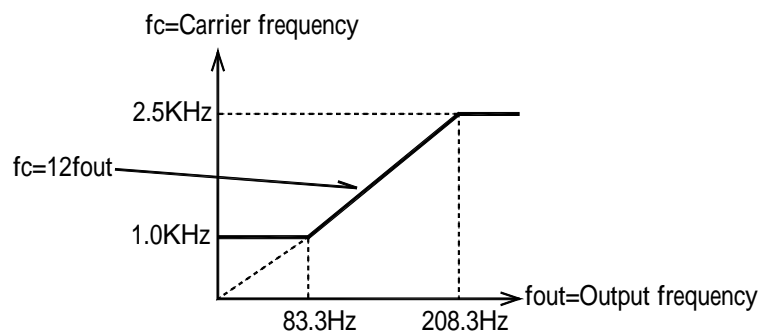

F46=8

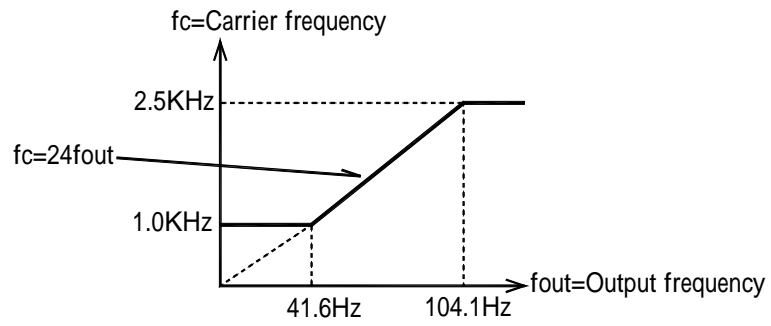

F46=9

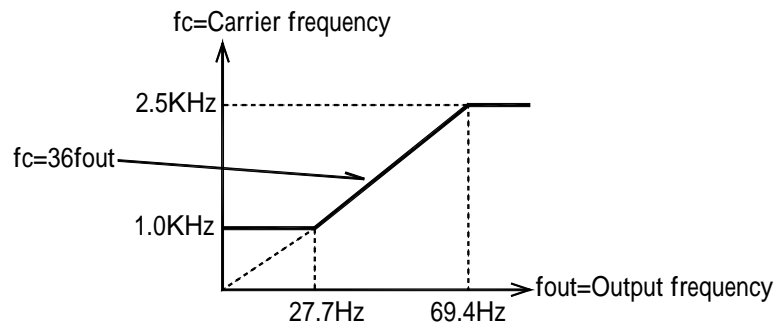

Factory setting varies according to inverter capacity.

Voltage Class (V)	Capacity (HP)	F46 Initial setting		Max. continuous output current (A)	Reduced current at carrier frequency 10kHz
		Setting	Carrier Frequency		
220V 3-phase Single-phase	1/4	4	10 kHz	1.6A	
	1/2	4	10 kHz	3.0A	
	1	4	10 kHz	5.0A	
	2	3	7.5 kHz	8.0A	7.0A
	3	3	7.5 kHz	11.0A	10.0A
	5	2	5 kHz	17.5A	16.5A
	7 1/2	2	5 kHz	25A	23A
440V 3-phase	1	3	7.5 kHz	3.4A	3.0A
	2	3	7.5 kHz	4.8A	4.0A
	3	3	7.5 kHz	5.5A	4.8A
	5	2	5 kHz	8.6A	8.1A
	7 1/2	2	5 kHz	14.8A	14A
	10	2	5 kHz	18A	17A

(1) Reduce continuous output current when changing carrier frequency to 4 (10 kHz) for the 220V class, 2HP or more and 440V class inverters. Refer to the table above for the reduced current.

(2) If the wiring distance is long, reduce the inverter carrier frequency as described below.

Wiring distance between inverter and motor	Up to 50m	Up to 100m	More than 100m
Carrier frequency (F46 setting)	10kHz or less (F46=1, 2, 3, 4, 7, 8, 9)	5kHz or less (F46=1, 2, 7, 8, 9)	2.5kHz or less (F46=1, 7, 8, 9)

(3) Carrier frequency is automatically reduced to 2.5kHz when reducing carrier frequency selection at low speed (F75) is set to 1 and output frequency 5Hz; Output current 110%.

(4) F75 Factory Setting: 0 (Disabled).

F47: Operation selection after momentary power loss

Automatic Restart after Momentary Power Loss (F47)

F47 Setting	Description
0 (Initial setting)	Continuous operation after momentary power loss not provided
1*	Continuous operation after power recovery within momentary power loss ridethru time 0.5s
2	Continuous operation after power recovery (Fault output not provided)

* Hold the operation signal to continue the operation after recovery from a momentary power loss.

F48: Fault reset**Continuing Operation by Automatic Fault Reset (F48)**

Set the inverter to restart and reset fault detection after a fault OC(overcurrent), GF(ground fault), OV(overvoltage) occurs. The number of self-diagnosis and retry attempts can be set at F48 up to 10.

The number of retry attempts are cleared to 0 in the following cases :

- (1) If no other fault occurs within 10 minutes after retry
- (2) When the fault reset signal is ON after the fault is detected
- (3) Power supply is turned OFF

F49: Jump frequency 1**F50: Jump frequency 2****F51: Jump frequency width****Jump Frequencies (F49~F51)**

This function allows the prohibition or “jumping” of critical frequencies so that the motor can operate without resonance caused by machine systems.

Jump Frequency 1 (F49)

Jump Frequency 2 (F50)

Jump Bandwidth (F51)

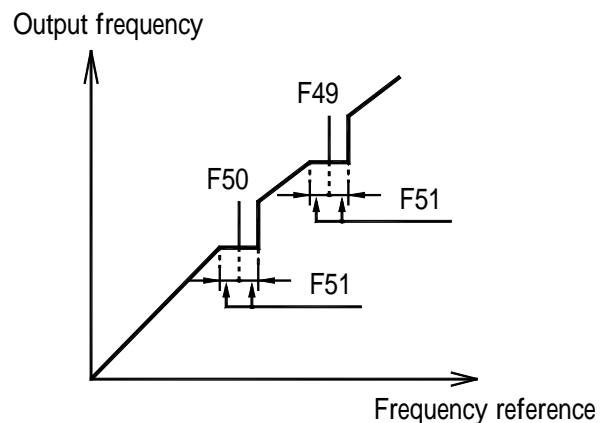

*When the setting of F49 F50 does not satisfy above condition, Err would be displayed on digital operator for one second and return to previous content before setting.

F52: DC injection braking current**F53: DC injection braking time at stop****F54: DC injection braking time at start****DC Injection Braking Current (F52)**

Set DC injection braking current in units of 1%. (Inverter rated current=100%)

DC Injection Braking Time at Stop (F53)

Set DC injection braking time at stop in units of 0.1s.

When the setting is 0, DC injection braking is not performed but inverter output is shut OFF (Base Block) at the timing of DC injection braking start.

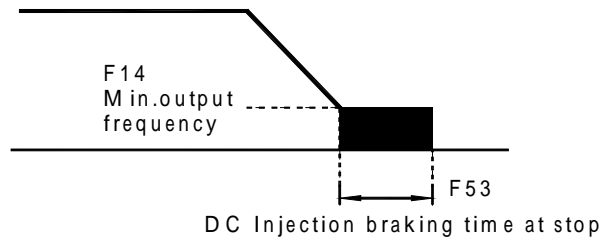

When coasting to a stop is specified in stopping method selection (F04=1), DC injection braking at stop does not operate.

DC Injection Braking at Start (F52, F54)

Restarts a coasting motor after stopping it. Set the DC injection braking time at start in F54 in units of 0.1 second. Constant F52 is DC injection braking current value. When the setting of F54 is "0", DC injection braking is not performed and acceleration starts from the minimum output frequency. When F52 is set to 0, acceleration starts from the minimum output frequency after the baseblocking for F54 setting time.

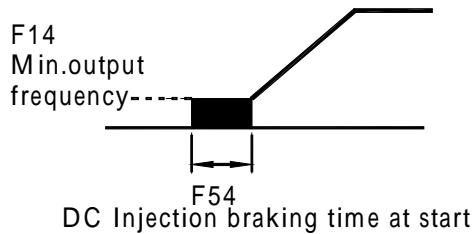

F55: Stall prevention (current limit)during decel

Stall Prevention during Deceleration (F55)

To prevent overvoltage during deceleration, the inverter automatically extends the deceleration time according to the value of main circuit DC voltage. When using an optional braking resistor, set F55 to 1.

F55 Setting	Stall prevention during deceleration
0 (Initial setting)	Provided
1	Not Provided (when braking resistor mounted)

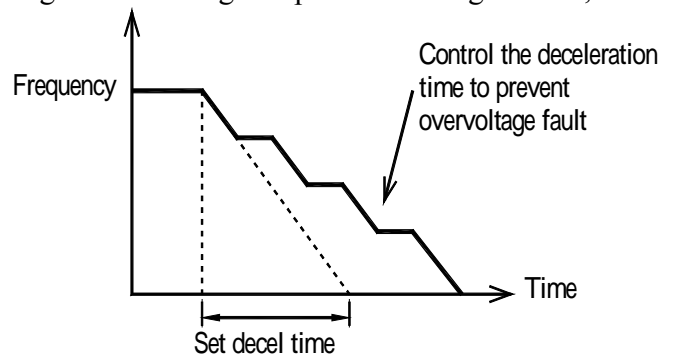

F56: Stall prevention (current limit)during accel
F57: Stall prevention (current limit)during running

Preventing Motor from Stalling (Current Limit)

Automatically adjusts the output frequency and output current according to the load to continue operation without stalling the motor.

● **Stall Prevention (Current Limit) Level during Acceleration (F56)**

Stall prevention (current limit) level during acceleration (F56) sets the stall prevention (current limit) level during acceleration in units of 1%. (Inverter rated current = 100%)

Factory setting: 170%. A setting of 200% disables the stall prevention (current limit) during acceleration.

During acceleration, if the output current exceeds the value set for F56, acceleration stops and frequency is maintained. When the output current goes down to the value set for F56, acceleration starts.

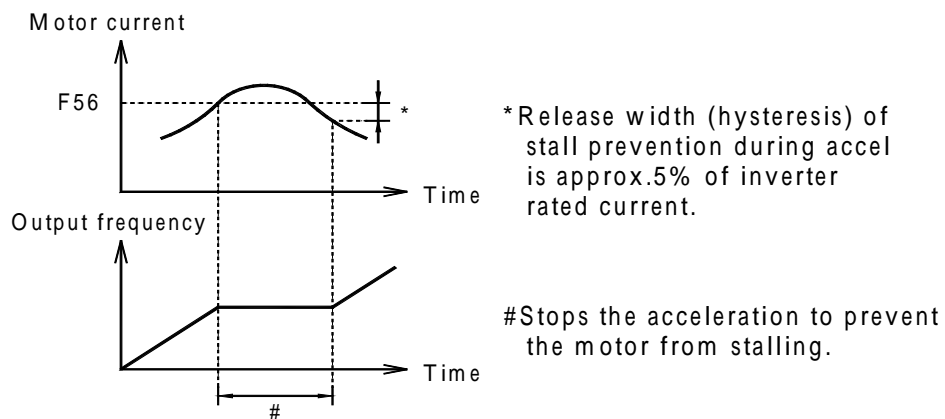

In the constant output area [output frequency max. voltage output frequency (F11)], following equation automatically decreases the stall prevention (current limit) level during acceleration.

Stall prevention (current limit) level during accel in constant output area

$$= \text{Stall prevention (current limit) level during accel (F56)} \times \frac{\text{Max. voltage output frequency(F11)}}{\text{Output frequency}}$$

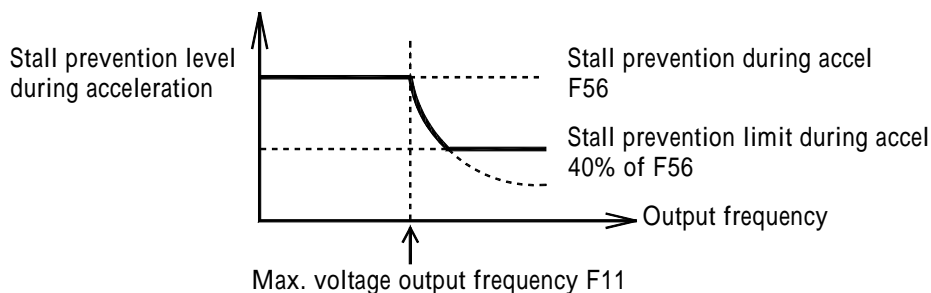

- **Stall Prevention (Current Limit) Level during Running (F57)**

Sets the stall prevention (current limit) level during running in units of 1%.

(Inverter rated current = 100%)

Factory setting: 160%. A setting of 200% disables the stall prevention (current limit) during running.

If stall prevention action current at agreed speed exceeds the value set for F57 for longer than 100msec, deceleration starts.

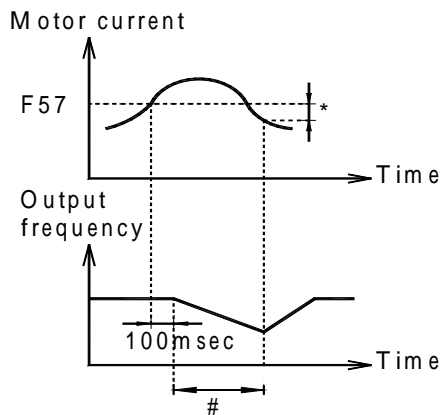

* Release width (hysteresis) of stall prevention during accel is approx.5% of inverter rated current.

Decreases frequency to prevent the motor from stalling.

F58: Frequency detection

- **Frequency Detection (F58)**

Frequency detection is effective when output terminal function selection F40 is set to 4 or 5.

- **Frequency Detection 1**

(Output frequency > Frequency detection level F58)

(F40 is set to 4)

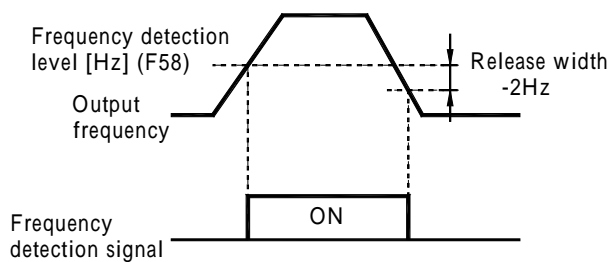

- **Frequency Detection 2**

(Output frequency < Frequency detection level F58)

(F40 is set to 5)

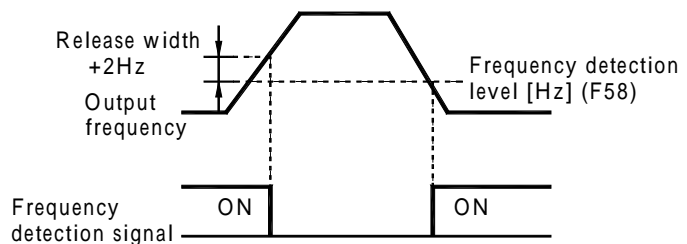

F59: Overtorque detection
F60: Overtorque detection level
F61: Overtorque detection time

F59 Setting	Description
0 (Initial setting)	Overtorque detection not provided
1	Detected during speed agree, (alarm). Operation continues after detection.
2	Detected during speed agree (fault). Operation stops during detection..
3	Detected during running. Operation continues after detection. (alarm).
4	Detected during running. Operation stops during detection. (fault).

- (1) To detect overtorque at accel/decel, set to 3 or 4.
- (2) To continue the operation after overtorque detection, set to 1 or 3. During detection, the digital operator displays “oL3” alarm.
- (3) To halt the inverter by a fault at overtorque detection, set to 2 or 4. At detection, the digital operator displays “oL3” fault .

Overtorque Detection Level (F60)

Sets the overtorque detection current level in units of 1%. (Inverter rated current = 100%).
 Factory setting: 160%

Overtorque Detection Time (F61)

If the time when motor current exceeds the overtorque detection level (F098) is longer than overtorque detection time (F099), the overtorque detection function operates.
 Factory setting : 0.1sec.

Torque Detection:

If an excessive load is applied to the machine, output current increase can be detected to output alarm signals to multi-function output terminals (MA, MB).

To output an overtorque detection signal, set output terminal function selection F040 to “overtorque detection” [Setting: 6 (a contact) or 7 (b contact)].

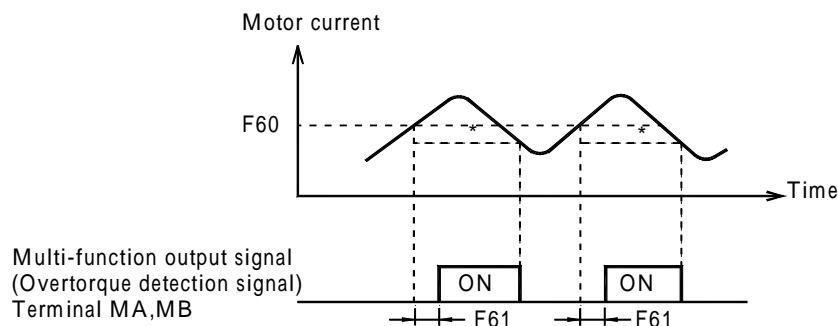

*Overtorque detection release width (hysteresis) is set at approx. 5% of inverter rated current.

F62: Memory selection of hold output frequency

F62 Setting	Description
0 (Initial Setting)	Output frequency is not recorded during HOLD.
1	When HOLD status is continued for 5 seconds or longer, the output frequency during HOLD is recorded and the inverter restarts at the recorded frequency.

Please refer to page 62.

F63: Torque compensation gain

Full-Range Automatic Torque Boost

Motor torque requirement changes according to load conditions. Full-range automatic torque boost adjusts voltage of V/F pattern according to the requirement. EI-450 automatically adjusts the voltage during constant-speed operation as well as acceleration. The required torque is calculated by the inverter and this ensures tripless operation and energy-saving effects.

$$\boxed{\text{Output voltage}} = \boxed{\text{Torque compensation gain (F63)}} \times \boxed{\text{Required torque}}$$

Operation

Normally, no adjustment is necessary for torque compensation Gain(F63). When the wiring distance between the inverter and the motor is long, or when the motor generates vibration, change the automatic torque boost gain.

In these cases, set the V/F pattern (F09 to F15).

Factory setting F63=1.0

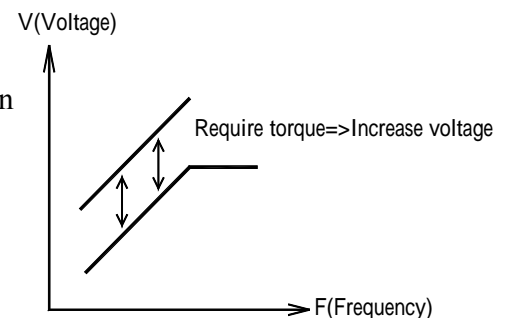

F64: Motor rated slip

F65: Motor no-load current

F66: Slip compensation gain

F67: Slip compensation primary delay time

Decreasing Motor Speed Fluctuation

Slip Compensation:

As the load becomes larger, motor speed is reduced and motor slip value is increased.

The slip compensating function controls the motor speed at a constant value even if the load varies.

When inverter output current is equal to the motor rated current F32, the compensation frequency is added to the output frequency.

Compensation frequency = Motor rated slip (F64)

$$\times \frac{\text{Output current} - \text{Motor no-load current (F65)}}{\text{Motor rated current (F32)} - \text{Motor no-load current (F65)}}$$

$$\times \text{Slip compensation gain (F66)}$$

Related constants

Constants No.	Name	Unit	Setting range	Initial setting
F32	Motor rated current	0.1A	0 ~ 120% of inverter rated current	*
F64	Motor rated slip	0.1Hz	0.0 ~ 20.0HZ	*
F65	Motor no-load current	1%	0 ~ 99%(100%=Motor rated current)	*
F66	Slip compensation gain	0.1	0.0 ~ 2.5	0.0
F67	Slip compensation primary delay time	0.1s	0.0 ~ 25.5s When 0.0s is set, delay time becomes 2.0s	2.0s

* Differs depending on inverter capacity.

Notes: 1. Slip compensation is not performed at output frequency < minimum output frequency (F14).

2. Slip compensation is not performed during regeneration.

3. Slip compensation is not performed when motor rated current (F32) is set to 0.0A.

F68: Timeover detection selection

F69: Setting unit selection of communications frequency reference/frequency monitor

F70: Slave address

F71: Baud rate selection

F72: Parity selection

F73: Send waiting time delay

F74: RTS control

MODBUS Communications

MODBUS is composed of a single MASTER (PLC) and SLAVES (1 to 32 EI-450 units). Communication between MASTER and SLAVE (serial communication) is controlled according to the MASTER program with the MASTER initiating communication and the SLAVE responding.

The MASTER sends a signal to one SLAVE at a time. Each SLAVE has a preregistered address No., and the MASTER specifies the number and conduct signal communications. The SLAVE receives the communications to carry out designated functions and reply to the MASTER.

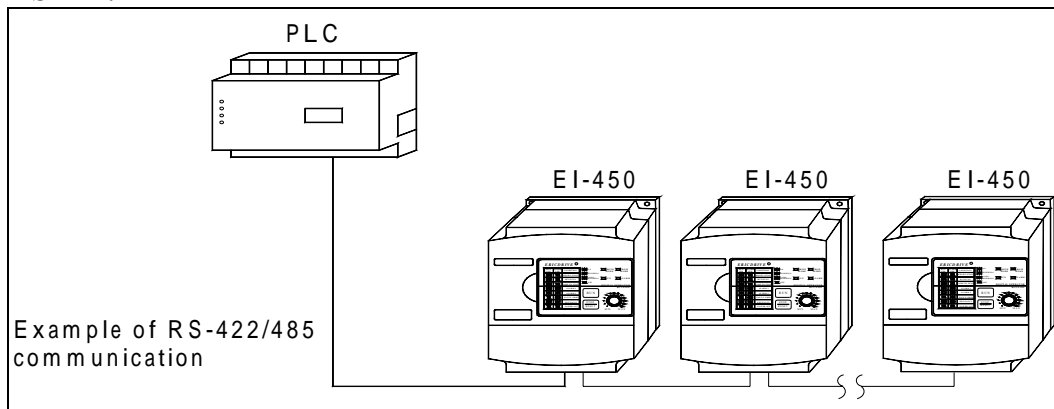

Communications Connection Terminal:

Use the following S+, S-, R+ and R- terminals for MODBUS communications. Change the termination resistor as shown below.

RS-422 communications Turn ON S2 ON/OFF

RS-485 communications Turn ON S2 ON/OFF switch of only the inverter at termination viewed from the PLC.

Note:

1. Separate the wiring for communication from the main circuit wiring or other power lines.
2. Use shielded cables for communication wiring; connect the shielded sheath to the ground terminal.
3. When communication is performed through RS-485, connect S+ and R+, S- and R-terminals outside the inverter.

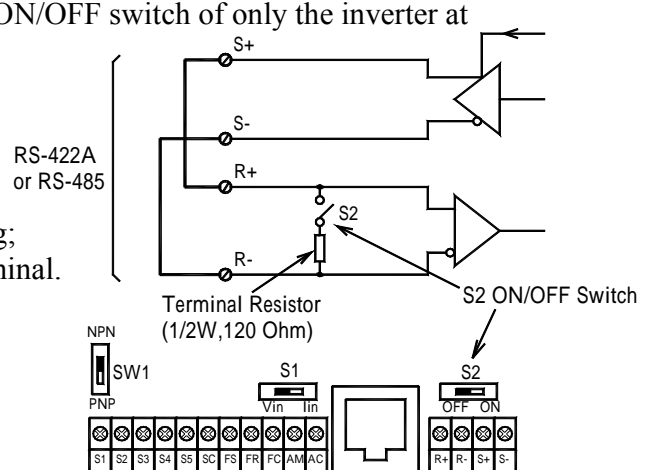

Procedure for Communications with PLC:

1. Connect the communication cable between the PLC and the EI-450 with the power supply turned OFF.
2. Turn the power ON.
3. Set the constants (F68 to F74) required for communication by using the digital operator.
4. Turn the power OFF once to verify that the digital operator displays have been completely erased.
5. Turn the power ON again.
6. Communications with the PLC starts.

Setting Constants Necessary for Communication:

Communication related constants must be set for PLC communication. Constants F68 to F74 cannot be set by communication. Always set them before performing communication.

Constant No.	Name	Description	Initial setting
F02	Operation reference selection	2 : MODBUS communication control	0
F03	Frequency reference selection	6 : MODBUS communication (Register No. 0002H)	0
F68	Timeover detection selection (Timeover: 2 sec.)	0 : Timeover detection (coast to a stop) 1 : Timeover detection (decelerates to a stop with speed reduction time 1) 2 : Timeover detection(decelerates to a stop with speed reduction time 2) 3 : Timeover detection(continuous operation, warning display) 4 : Timeover detection not provided	0
F69	MODBUS frequency reference and frequency monitor unit	0 : 0.1Hz 1 : 0.01Hz 2 : 30000/100%(30000=Max. output frequency) 3 : 0.1%	0
F70	MODBUS slave address	Setting range: 0 ~ 32 (0 : The slave does not respond to the command from the master when set to 0)	0
F71	MODBUS BPS selection	0 : 2400bps 1 : 4800bps 2 : 9600bps 3 : 19200bps	2
F72	MODBUS parity selection	0 : even parity 1 : odd parity 2 : no parity	0
F73	Send waiting time	Setting range : 10ms ~ 65ms Setting unit : 1ms	10ms
F74	RTS control	0 : RTS control 1 : No RTS control(RS-422A : 1 to 1 communication)	0

Message Format:

Please refer to EI-450 INVERTER MODBUS RTU Instruction Manual for details of message format.

Communication Self Test (F39=35):

EI-450 is provided with a function to perform self-diagnosis for operation check of the serial communication I/F circuit. This function is called self-test. In the self-test, connect the sending terminal with the receiving terminal in the communication section. It assures if the data received by EI-450 is not being changed. It also checks if the data can be received normally.

Carry out the self-test in the following procedure.

1. Turn ON the EI-450 power supply. Set constant F39 to 35 (self-test).
2. Turn OFF the EI-450 power supply.
3. Make the following wiring with the power supply turned OFF.
4. Turn ON the EI-450 power supply.

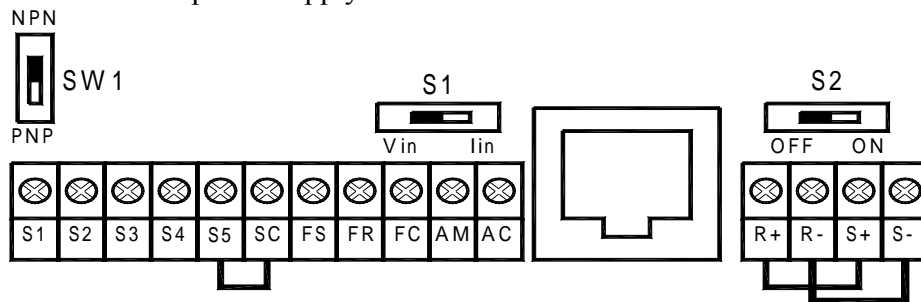

Normal operation: Operator displays frequency reference value.

Faulty operation: Operator displays “CE” fault; signal is turned “ON” and inverter ready.
Signal is turned OFF

F75: Carrier frequency at low speed

Please refer to page 68.

F76: Constants COPY function selection**F77: Constants READ prohibit selection**

Using Constant Copy Function.

Constant Copy Function:

RCU-450P is an optional digital operator of EI-450 and it can store constants for one inverter. A backup power supply is not necessary since EEPROM is used.

Constant copy function is possible only for the inverters with same product series, (it is impossible to copy constants between EI-450 \longleftrightarrow EI-500), same power supply specifications (220V class or 440 class), same motor capacity.

The prohibition of the digital operator RCU-450P reading of constants from the inverter can be set at F77=0, factory setting. The constant data cannot be changed when this constant is set.

During COPY, if there is any fault occurring, PRGM Indicator blinks and constants copy function continues operation.

Constant Copy Function Selection (F76):

Depending on the setting of F76 for constant copy function selection, the following functions are available:

- Read all the constants from the inverter (READ) and store them in EEPROM in the digital operator RCU-450P.
- Copy the constants stored in the digital operator RCU-450P to the inverter (COPY).
- Verify that the constants in the digital operator RCU-450P and the constants in the inverter are the same (VERIFY).
- Display the model number, the maximum applicable motor capacity and the voltage class of the inverter that has the constants stored in the digital operator.

Constant No.	Name	Unit	Setting range	Initial setting
F76	Constant copy function selection		rdy: READY rEd: READ Cpy: COPY vFy: VERIFY vA: Inverter capacity display Sno: Model No. display	rdy

Prohibiting Constant Read Selection (F77):

Selects this function to prevent accidentally overwriting the constants stored in EEPROM or in the digital operator RCU-450P. Reading is not possible when F77 is set to 0. The constant data stored in the digital operator are safe from accidental overwriting. When reading is performed while F77 is set to 0, “PrE” will blink. Press or and return to constant No. display.















Constant No.	Name	Unit	Setting range	Initial setting
F77	Constant read prohibit selection	1	0: READ prohibited 1: READ allowed	0

READ Function (READ):

Reads out the constants in batch from the inverter and stores them in EEPROM inside the digital operator RCU-450P. When the read-out is executed, the previously stored constants data in the EEPROM are cleared and replaced with the newly entered constants.



1. F01=1; Enable the setting of F01 to F79 for reading and writing.
2. F77=1; Allow the read-out and write-in of digital operator RCU-450P.
3. F76= "Constants read-out"; store constants from the inverter in EEPROM inside the digital operator RCU-450P.
4. F77=0; Prohibit digital operator RCU-450P read-out.

Example: Copy the constants from inverter to RCU-450P:

	Description	Operator Display
F01~F79 Setting	Press DSPL key and PRGM ON	F01 (Or other constants)
	Press ENTER key to display content	0 (Display)
	Press  or  key to 1	1 (Blinking)
	Press ENTER key, write it in	1 (Display for 1 second) F01 (Display current constant)
F77 set as READ allowed	Press  or  key to F77	F77
	Press ENTER key to display content	0 (Display)
	Press  or  key to 1	1 (Blinking)
	Press ENTER key, write it in	1 (Display for 1 second) F77 (Display current constant)
F76 Function selection READ(rEd) execution	Press  or  key to F76	F76
	Press ENTER key to display content	rdy (Display)
	Press  or  key to rEd	rEd (Display)
	Press ENTER key	rEd (Execute READ, Blinking) End (READ completed)
F77set as READ prohibited	Press DSPL or ENTER key	F76 (Display current constant)
	Press  or  key to F77	F77
	Press ENTER key to display content	1 (Display)
	Press  or  key to 0	0 (Blinking)
	Press ENTER key to display content	0 (Display for 1 second) F77 (Display current constant)

COPY Function (COPY):

Writes the constants stored inside the digital operator RCU-450P in batch to inverter.

Write-in is possible only for the inverters with same product series, power supply specifications. When satisfying the above condition, “VAE” will appear when the capacity of inverters differs. Press  to continue COPY function and press  to stop COPY function.

Following constants are not written if the inverter capacity is different.

Constant No.	Name
F09~ F15	V/F Setting
F32	Motor rated current
F46	Carrier frequency reference
F64	Motor rated slip
F65	Motor no-load current







“Write-in” Function Steps:

1. F01=1;
2. F76= “Cpy”

A setting range check and matching check for the written-in constants are executed after the constants are written from the digital operator to the inverter. If any constant error is found, the written constants are discarded and the constants stored before writing are restored.

During write- in, CPy blinks and End shows when it is completed.

Example: Write the constants in RCU-450P in the inverter.



	Description	Operator Display
F01~F79 Setting	Press DSPL key and PRGM ON	F01 (Or other constants)
	Press ENTER key to display content	0 (Display)
	Press  or  key to 1	1 (Blinking)
	Press ENTER key, write it in	1 (Display for 1 second)
F76 Function selection COPY (CPy) execution		F01 (Display current constant)
	Press  or  key to F76	F76
	Press ENTER key to display content	rdy (Display)
	Press  or  key to CPy	CPy (Display)
	Press ENTER key	CPy (Execute COPY, Blinking)
	Press DSPL or ENTER key	End (COPY completed)
		F76 (Display current constant)

VERIFY Function (VERIFY):







Collates the constants stored in the digital operator RCU-450P with the constants in the inverter. As well as write-in, VERIFY is possible only for the inverters with same product series, power supply specifications. When the constants stored in the digital operator correspond to those in the inverter, “End” is displayed. If they do not respond, an unmatched constant No. or a constant value is displayed.

“VERIFY” Function Steps:

1. F01=1;
2. F76= “vFy”;
3. If the constants match, operator will show “ End”
4. If the constants do not match, operator will display “ unmatched constant No.”

- a. Press  to display “ constant value in the inverter”
- b. Then press  to display “constant value in the digital operator”
- c. Then press  to continue to display the next “unmatched constant No.”
- d. Finally, display “ End” and it is done.

Example: Verify the constants in RCU-450P and in the inverter

	Description	Operator Display
F01~F79 Setting	Press DSPL key and PRGM ON	F01 (Or other constants)
	Press ENTER key to display content	0 (Display)
	Press  or  key to 1	1 (Blinking)
	Press ENTER key, write it in	1 (Display for 1 second)
F76 Function selection VERIFY(vFy) execution	Press  or  key to F76	F01 (Display current constant)
	Press ENTER key to display content	F76 (Display)
	Press  or  key to vFy	rdy (Display)
	Press ENTER key	vFy (Display) vFy (Execute VERIFY, Blinking)
Unmatched constant value Constant in inverter	Press ENTER key	F01 (Blinking)
	Press ENTER key	60.0 (Blinking)
Constant in RCU-450P Continue Verify	Press ENTER key	50.0 (Blinking)
	Press  key	vFy (Execute VERIFY, Blinking)
	Press DSPL or ENTER key	End (VERIFY completed)
		F76 (Display current constant)

While display constant setting value or unmatched value,  key can stop verify and display “End”. Current constant can be displayed by pressing DSPL key or ENTER key.

Inverter Capacity:

Reads the voltage class and maximum applicable motor capacity stored in digital operator RCU-450P on the inverter.

Example: Read the voltage class and maximum applicable motor capacity stored in digital operator RCU-450P

Description		Operator Display
F01~F79 Setting	Press DSPL key and PRGM ON	F01 (Or other constants)
	Press ENTER key to display content	0 (Display)
	Press ▲ or ▼ key to 1	1 (Blinking)
	Press ENTER key, write it in	1 (Display for 1 second)
		F01 (Display current constant)
F76 Function selection Inverter capacity reading(vA) execution	Press ▲ or ▼ key to F76	F76
	Press ENTER key to display content	rdy (Display)
	Press ▲ or ▼ key to vA	vA (Display)
	Press ENTER key	20.7 (Display 20.7 capacity)
	Press DSPL or ENTER key	F76 (Display current constant)

Capacity
Display:

20.7

2: 220V 0.2=0.2KW(1/4HP), 0.7=0.7KW(1HP), 3.7=3.7KW(5HP)
 4: 440V 0.4=0.4KW(1/2HP), 1.5=1.5KW(2HP), 5.5=5.5KW(7.5HP)
 2.2=2.2KW(3HP), 7.5=7.5KW(10HP)











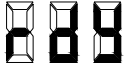

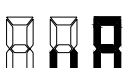

Inverter Model No.:



Read the model No. stored in the digital operator RCU-450P on the inverter.

Example: Read the model No. stored in the digital operator RCU-450P on the inverter.

Description		Operator Display
F01~F79 Setting	Press DSPL key and PRGM ON	F01 (Or other constants)
	Press ENTER key to display content	0 (Display)
	Press ▲ or ▼ key to 1	1 (Blinking)
	Press ENTER key, write it in	1 (Display for 1 second)
		F01 (Display current constant)
F76 Function selection inverter model no. reading execution (Sno)	Press ▲ or ▼ key to F76	F76
	Press ENTER key to display content	rdy (Display)
	Press ▲ or ▼ key to Sno	Sno (Display)
	Press ENTER key	450 (Display EI-450 inverter)
	Press DSPL or ENTER key	F76 (Display current constant)

Digital Operator (RCU-450P) Display and User Instruction

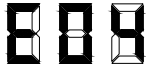
Display	Description	Solution
	Display: Constants COPY selection ready.	
	Display: Constants READ selected. Blinking: Execute READ.	
	Display: Constants COPY selected. Blinking: Execute COPY.	
	Display: Constants VERIFY selected Blinking: Execute VERIFY.	
	Display: Inverter capacity reading selected.	
	Display: Inverter model no. reading selected.	
	Display: READ, COPY, VERIFY completed.	
	Blinking: F77 set as READ prohibited. Constants READ selected.	Set F77=1 to execute READ.
	Blinking: During READ, power supply of main circuit is too low.	Proper power supply to execute READ.
	Blinking: Check Sum of digital operator RCU-450P is at fault.	Execute READ and VERIFY.
	Blinking: COPY function between inverters of different models.	Use the inverter of the same capacity.
	Blinking: No recorded constants in digital operator	Execute READ.
	Blinking: READ/VERIFY function between inverters of different voltage classes.	Use the the inverter of the same voltage class.
	Blinking: During COPY, power supply of main circuit is too low.	Proper power supply to excute COPY.

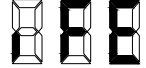
Display	Description	Solution
	Blinking: Check sum of inverter is at fault.	Return to initial setting or replace the inverter unit.
	Blinking: VERIFY function between inverters of different capacities.	Press ENTER key to stop VERIFY. After VERIFY, press STOP key to reset.
	Blinking: Fault between inverter and operator.	Check the communication between inverter and operator. Re-execute READ/COPY.

CHAPTER 5 MAINTENANCE AND INSPECTION

Periodical Inspection

Periodically inspect the inverter as described in the following table to prevent accidents and to ensure high performance with high-reliability.

Items for Checks		
Location to Check	Check for	Solution
Terminals, unit mounting screws, etc.	Connection hardware is properly seated and securely tightened	Properly seated and tighten hardware.
Heatsink	Built up dust, dirt, and debris	Blow with dry compressed air: 39.2 ~ 58.8 10^4 Pa(4 ~ 6kg/cm ²) pressure.
Printed circuit board	Accumulation of conductive material or oil mist	Blow with dry compressed air: 39.2 ~ 58.8 10^4 Pa(4 ~ 6kg/cm ²) pressure. If dust or oil cannot be removed, replace the inverter unit.
Power elements and smoothing capacitor	Abnormal odor or discoloration	Replace the inverter unit.
Cooling fan	Abnormal noise or vibration Cumulative operation time exceeding 20,000 hours	Replace the cooling fan.

Part Replacement

Inverter's maintenance periods are noted below. Keep them as reference.

Part Replacement Guides

Part	Standard Replacement Period	Replacement Method
Cooling fan	2 ~ 3 years	Replace with new part.
Smoothing capacitor	5 years	Replace with new part.
Breaker relays		Determine need by inspection.
Fuses	10 years	Replace with new part.
Aluminum capacitors on PCBs	5 years	Replace with new board.

Usage conditions are as follows:

- Ambient temperature: Yearly average of 30
- Load factor: 80% max.
- Operating rate: 12 hours max. per day

CHAPTER 6 FAULT DIAGNOSIS

Protective and Diagnostic Functions

This section describes the alarm and fault displays, the fault conditions, and the corrective actions to be taken if the EI-450 malfunctions.

Inverter alarms are classified into alarm display and fault display.

Alarm display: When a minor fault occurs in the inverter, the Digital Operator flashes the display. In this case, the operation is continued, and restored automatically as soon as the cause is removed. Multi-function output can output the minor fault status to external devices.

Fault display: When a major fault occurs in the inverter, the protective function operates, and the Digital Operator lights the display and shuts off the output to stop the inverter. The fault can be output as a fault output to the external devices by multi-function output.

To reset the fault, use  key of Digital Operator or cycle the power after taking the second corrective action.

Status Indicator Description:



: ON



: Blinking





: LONG Blinking



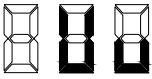

: OFF

Alarm Display:





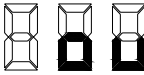
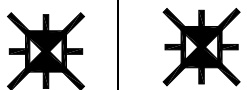

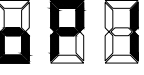

Alarm Display and Contents

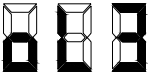
Alarm Display (Digital Operator)		Inverter Status	Explanation	Cause and Corrective Action
RCU-450(P)	RCU-450(P)			
7-segment Display	Status Indicator			
RUN LED	ALARM LED			
		Warning	UV (Main circuit low voltage) Main circuit DC voltage drops below the low-voltage detection level while the inverter output is OFF. 220V:Main circuit DC voltage drops below approx. 200V. (160V for single phase) 440V:Main circuit DC voltage drops below approx. 400V.	Check the following : 1. Power supply voltage. 2. Main circuit power supply wiring is connected. 3. Terminal screws are securely tightened.
Blinking	Long Blinking	Fault contacts do not change state.		



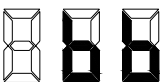

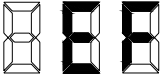
Alarm Display and Contents

Alarm Display (Digital Operator)		Inverter Status	Explanation	Cause and Corrective Action
RCU-450(P)	RCU-450(P)			
7-segment Display	Status Indicator			
	RUN LED ALARM LED			
		Warning	OV (Main circuit over voltage) Main circuit DC voltage exceeds the overvoltage detection level while the inverter output is OFF. Detection level: approx. 410V or more (approx. 820V for 440 class).	Check the power supply voltage.
			OH (Cooling fin overheat) Intake air temperature rises while the inverter output is OFF.	Check the intake air temperature.
			CAL (MODBUS communications waiting) Correct data has not been received from the PLC when the constant F02 is 2 or F03 is 6 and power is turned ON.	Check communication devices, and transmission signals.
			OPE (constants setting error when the constants setting is performed through the MODBUS) OPE1: Two or more values are set for multifunction input selection. (F36~F39) OPE2: Relationship among V/F constants is not correct (F09~F14) OPE3: Value of motor rated current exceeds 120% of inverter rated current. (F32) OPE4: Upper / lower limit of frequency reference is reversed. (F30~F31) OPE5: Incorrect setting value of jump frequency reference (F49~F50)	Check the setting values.
	Long Blinking	Fault contacts do not change state.		

Alarm Display and Contents

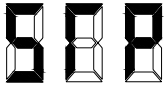
Alarm Display (Digital Operator)		Inverter Status	Explanation	Cause and Corrective Action
RCU-450(P)	RCU-450(P)			
7-segment Display	Status Indicator			
	RUN LED ALARM LED			
 Blinking	 	Warning Fault contacts do not change state.	OL 3 (Over torque detection) Motor current exceeds the preset value in constant F60	Reduce the load, and expand the accel / decel time.
 Blinking	ON Long Blinking		SER (Sequence error) Inverter receives LOCAL / REMOTE select command or communication / control circuit terminal changing signals from the multifunction terminal while the inverter is outputting.	Check the external circuit (sequence).
 Blinking	  ON Long Blinking		BB (External baseblock) Baseblock command at multi-function terminal is active, The inverter output is shut OFF (motor coasting). Temporary condition is cleared when input command is removed.	Check the external circuit (sequence).
 Blinking	or   Long Blinking Long Blinking		EF (Simultaneous FWD/REV run commands) When FWD and REV run commands are simultaneously input for over 500ms, the inverter stops according to constant F04.	Check the external circuit (sequence).

Alarm Display and Contents

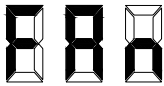
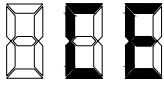

Alarm Display (Digital Operator)		Inverter Status	Explanation	Cause and Corrective Action	
RCU-450(P)	RCU-450(P)				
7-segment Display	Status Indicator				
	RUN LED ALARM LED				
 Blinking	 ON or  Long Blinking	 Long Blinking or  Long Blinking	Warning Fault contacts do not change state.	STP (Operator function stop) STOP/RESET key is pressed during running by the control circuit terminals FWD / REV command, or by the run command from communications. Inverter stops according to constant F04. STP(Emergency stop) Inverter receives emergency stop alarm signal. Inverter stops according to constant F04.	Open FWD/REV command of control circuit terminals . Check the external circuit (sequence).
 Blinking				FAN(Cooling fan fault) Cooling fan is locked.	Check the cooling fan and if the cooling fan wiring is not connected.
 Blinking				CE (MODBUS) communications fault	Check the communication devices or communication signals.

Fault Display:

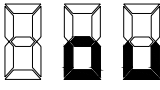
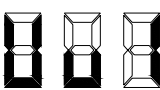

Fault Display and Contents

Fault Display (Digital Operator)		Inverter Status	Explanation	Cause and Corrective Action
RCU-450(P)	RCU-450(P)			
7-segment Display	Status Indicator			
RUN LED	ALARM LED			
		Protective Operation Output is shut OFF and motor coasts to a stop.	OC (Overcurrent) Inverter output current momentarily exceeds approx. 200% of rated current.	Short circuit or grounding at inverter output side. Excessive load GD ² . Extremely rapid accel/decel time. constants F19 to F22 Special motor used. Starting motor during coasting. Motor of a capacity greater than the inverter rating has been started. Magnetic contactor open/closed at the inverter output side.

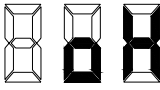
Fault Display and Contents

Fault Display (Digital Operator)		Inverter Status	Explanation	Cause and Corrective Action
RCU-450(P)	RCU-450(P)			
RCUS-450				
7-segment Display	Status Indicator			
	RUN LED	ALARM LED		
			<p>OV (Main circuit overvoltage) Main circuit DC voltage exceeds the overvoltage detection level because of excessive regenerative energy from the motor. 220V: Stops at main circuit DC voltage below approx. 410V. 440V: Stops at main circuit DC voltage approx. 820V</p>	<p>Insufficient decel time.(constants F17 and F18) Lowering of overhauling load. Increase decel time. Connect optional braking resistor.</p>
			<p>Protective Operation Output is shut OFF and motor coasts to a stop.</p>	<p>UV1 (Main circuit low voltage) Main circuit DC voltage drops below the low-voltage detection level while the inverter output is ON. 220V: Stops at main circuit DC voltage below approx. 200V (160V for single-phase) 440V: Stops at main circuit DC voltage approx. 400V</p> <p>Reduction of input power supply voltage. Open phase of input supply. Occurrence of Momentary power loss. Check the power supply voltage, wiring and screws.</p>
	OFF	Long Blinking	<p>OH (Cooling fin overheat) Temperature rise because of inverter overload operation or intake air temperature rise.</p>	<p>Excessive load. Improper V/F pattern setting. Insufficient accel time if the fault occurs during acceleration. Intake air temperature exceeding 50 °C. Cooling fan stops. Check the load size, V/F pattern setting, intake air temperature.</p>

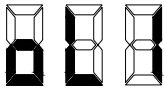
Fault Display and Contents

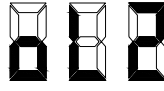
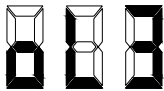
Fault Display (Digital Operator)		Inverter Status	Explanation	Cause and Corrective Action	
RCU-450(P)	RCU-450(P)				
7-segment Display	Status Indicator				
RUN LED	ALARM LED				
			Protective Operation Output is shut OFF and motor coasts to a stop.	OL1 (Motor overload) Motor overload protection operates by built-in electronic thermal overload relay. Check the load size or V/F pattern setting. Set the motor rated current shown on the nameplate by constant F32.	
	OFF	Long Blinking			OL2 (Inverter overload) Inverter overload protection operates by built-in electronic thermal overload relay. Check the load size or V/F pattern setting. Check the inverter capacity.
					OL3 (Overtorque detection) V/F mode: Inverter output current exceeds the preset value in constant F60 increase the value of constant F60 up to the highest value allowed for the machine.

Fault Display and Contents

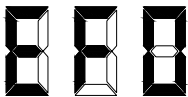
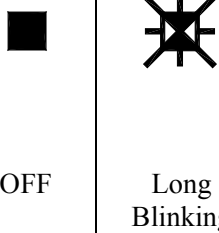
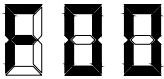
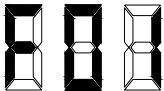
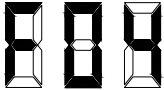
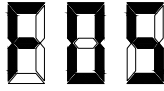
Fault Display (Digital Operator)		Inverter Status	Explanation	Cause and Corrective Action
RCU-450(P)	RCU-450(P)			
7-segment Display	Status Indicator			
	RUN LED ALARM LED			
		Protective Operation Output is shut OFF and motor coasts to a stop.	EF : (External fault) Inverter receives an external fault input from control circuit terminal. EF0: External fault reference through MODBUS communications. EF2: External fault input command from control circuit terminal S2 EF3: External fault input command from control circuit terminal S3 EF4: External fault input command from control circuit terminal S4 EF5: External fault input command from control circuit terminal S5	Check the external circuit (sequence).
	OFF		CPF-00 Initial memory fault is detected.	Cycle power. If the fault remains, replace the digital operator or inverter.
	OFF		CPF-01 ROM error is detected.	Cycle power. If the fault remains, replace the digital operator or inverter
	OFF		CPF-04 EEPROM fault of inverter control circuit is detected.	Record all constant data and initialize the constants. Cycle power. If the fault remains, replace the inverter.
	OFF		CPF-05 AD converter fault is detected.	Cycle power. If the fault remains, replace the inverter.

Fault Display and Contents

Fault Display (Digital Operator)		Inverter Status	Explanation	Cause and Corrective Action
RCU-450(P)	RCU-450(P)			
RCUS-450				
7-segment Display	Status Indicator			
	RUN LED	ALARM LED		
			Protective Operation Output is shut OFF and motor coasts to a stop.	CPF-07 Operator control circuit (EEPROM or AD converter) fault. Cycle power after checking the digital operator is securely mounted. If the fault remains, replace the digital operator or inverter.
	OFF	Long Blinking		
	 OFF or 	 ON	Stop according to constant F04.	STP (Emergency stop) Inverter receives emergency stop alarm signal. Inverter stops according to constant F04. Check the external circuit (sequence).
	 OFF	 OFF		

APPENDIX

Recommended Peripheral Devices

It is recommended that the following peripheral devices be mounted between the AC main circuit power supply and EI-450 input terminals R/L1, S/L2, and T/L3.

- MCCB (Molded-case circuit breaker):
A circuit breaker should be connected for wiring protection.
- Magnetic contactor:
Mount a surge suppressor on the coil.
To assure optimum inverter life when using a magnetic contactor to start and stop the inverter, do not exceed one stop per hour.

Recommended MCCB and Magnetic Contactor

220V Class 3-phase

EI-450 model	01L	02L	03L	05L	07L
Inverter capacity (HP)	1	2	3	5	7.5
Rated output current (A)	5	8	11	18	25
Max. MCCB rating (A)	15A	20A	20A	30A	30A
Magnetic contactor	CN-11	CN-16	CN-16	CN-18	CN-25

220V Class Single-phase

EI-450 model	P2L	P4L	S1L	S2L	S3L
Inverter capacity (HP)	1/4	1/2	1	2	3
Rated output current (A)	1.6	3	5	8	11
Max. MCCB rating (A)	15A	15A	20A	20A	30A
Magnetic contactor	CN-11	CN-11	CN-11	CN-16	CN-16

440V Class 3-phase

EI-450 model	01H	02H	03H	05H	07H	10H
Inverter capacity (HP)	1	2	3	5	7.5	10
Rated output current (A)	2.5	4	6	8	15	18
Max. MCCB rating (A)	15A	15A	15A	20A	30A	30A
Magnetic contactor	CN-11	CN-11	CN-11	CN-16	CN-16	CN-25