

INVERTEK® SUNWIDE SERIES

SW-10CL/ SW-20CL/ SW-30CL/ SW-45CL
Installation and Operation Manual



Solar Battery Charging

Load Control

Lighting Control



MANUAL VER. 2, 1008



1-1 Introduction

The SunWide is an advanced design using a microcontroller for digital accuracy and fully automatic operation. Each model unit can be used for 12V, 24V and 48V system and can be operated at three major functions including solar charging, load control and lighting control. The PWM battery charging has been optimized for longer battery life and the state-of-the-art auto detector of day and night has been precisely applied to log the different length of night hours for lighting control no matter where and when (the North or the South, winter or summer) SunWide is installed. Many specifications of the SunWide are unique and designed for user-friendly operation. Please take the time to read this operator's manual and follow the instruction step by step to help you make full use of many functions that the SunWide can provide to your solar lighting system.

1-2 Safety Instruction

- This manual contains important instructions that should be followed during installation and maintenance of the SunWide controller.
- Be very careful when working with batteries. Lead acid batteries can generate explosive gases, and short circuits can draw thousands of amps from the battery. Read all instructions provided with the battery.
- Do not exceed the rated current ratings of the controller.
- Do not exceed a battery voltage of 48V (nominal). Do not use a battery less than 12V.
- Charge only 12, 24, or 48 volt lead-acid batteries when using the standard battery charging programs or NI-CAD batteries when DIP Switch number 3~5 is in the ON position in the SunWide.
- DO NOT short circuit the PV array or load while connected to the controller. This will damage the controller.
- The controller should be protected from direct sunlight. Ensure adequate space for air flow around the controller.
- Do not install a SunWide in a sealed compartment with batteries.
- Never allow the solar array to be connected to the SunWide with the battery disconnected. This can be a dangerous condition with high open-circuit solar voltage present at the terminals.
- Pressure terminal connectors are not required. Use only copperwire with minimum 75°C insulation rating and between 10 AWG (5.2 mm²) and 14 AWG (2.1 mm²) gage.
- The negative system conductor should be properly grounded. Grounding should comply with local codes.

1-3 Specifications

MODEL	SW-10CL	SW-20CL	SW-30CL	SW-45CL
ELECTRICAL				
System voltage ratings	12, 24, 48 Vdc			
Current ratings- Battery Charge Control	10A	20A	30A	45A
Current ratings- Load Control/ Lighting Control	10A	20A	30A	45A
Accuracy	12/24V: $\leq 0.1\% \pm 50\text{ mV}$ 48V: $\leq 0.1\% \pm 100\text{ mV}$			
Min. voltage to operate	9 V			
Max. solar array Voc	140 V			
Max. operating voltage	68 V			
Total current consumption	While operating -25mA, at idle -3mA			
High temp shutdown	90°C disconnect solar 90°C disconnect load / diversion load 70°C reconnect solar / load / diversion load			
LVD	11.1V (initial setting) User select: 10.5V, 11.3V, 11.5V, 11.7V, 11.9V, 12.1V, 12.3V for 12V system Twice or four times of 12V is for 24V and 48V system			
LVR	12.6V (initial setting) User select: 12.0, 12.8V, 13.0V, 13.2V, 13.4, 13.6, 13.8 for 12V system Twice or four times of 12V is for 24V and 48V system			
Overload Capacity	150% of rated current for transient surge			
BATTERY CHARGING / Built-in BTS				
Charge algorithm	PWM, constant voltage			
Temp comp. coefficient	-5mV/°C / cell (25°C ref)			
Temp comp. range	0°C to +50°C			
Temp comp. setpoints	PWM, float, equalize (with BTS)			
MECHANICAL				
Weight	0.3 Kgs		0.4 Kgs	0.7 Kgs
Power terminals	10A Rated	20A Rated	30A Rated	45A Rated
ENVIRONMENTAL				
Ambient temperature	-40 to +45°C			
Storage temperature	-55 to +85°C			
Humidity	100% (NC)			
Enclosure	Indoor & vented, (powder coated steel)			
OPTIONS				
Remote Panel	Optional LCD display for SW-30CL and SW-45CL			
Specifications subject to change without notice				

1-4 SW-10CL, SW-20CL, SW-30CL Mounting Dimension

Unit: mm

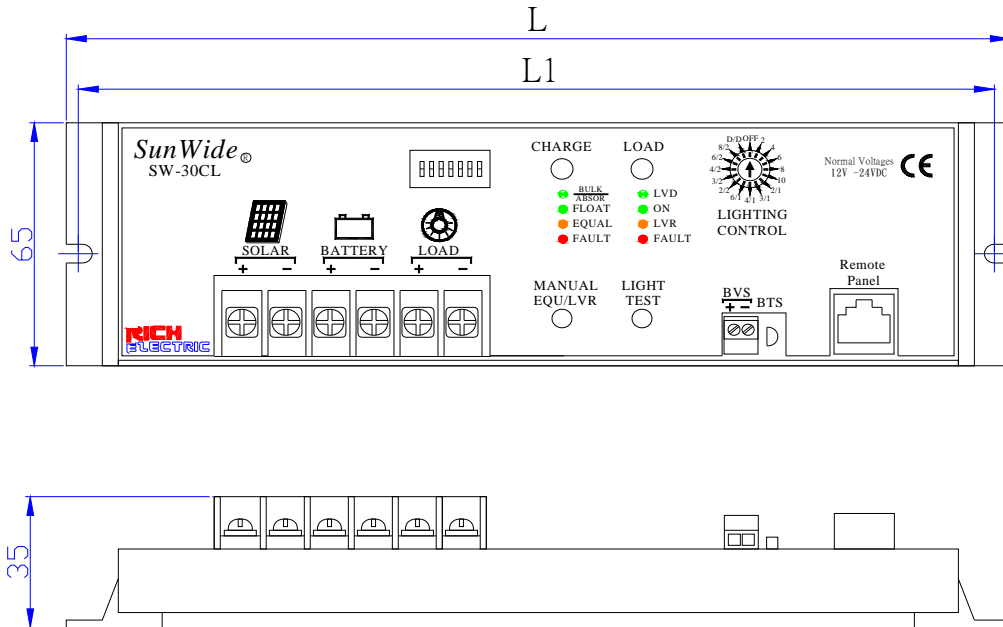

Length Model	L	L1
SW-10CL / SW-20CL	168 mm	161 mm
SW-30CL	236 mm	229 mm

1-5 RP-SW Remote Panel Dimension

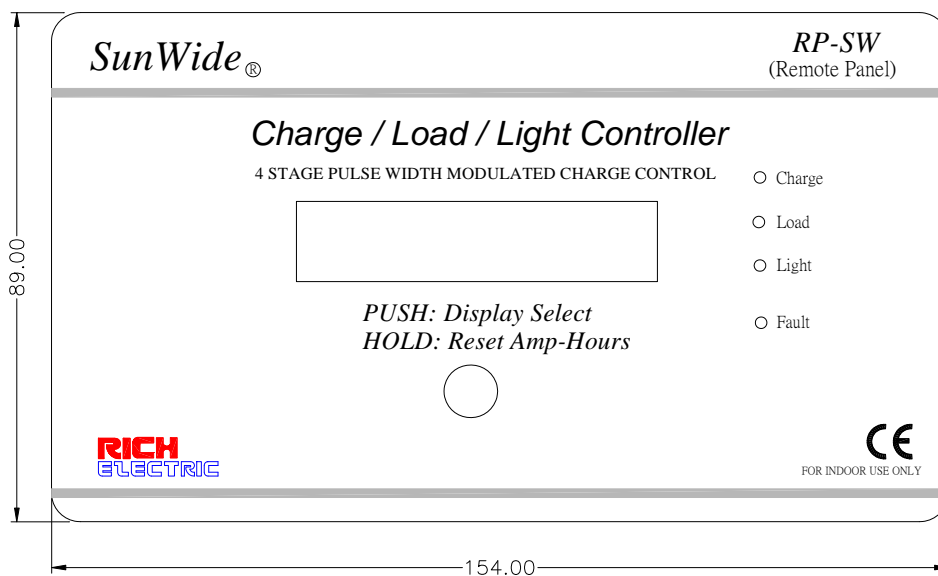

1-6 Installation Overview

The installation is straight forward but it is important that each step is done correctly and safely. A mistake can lead to dangerous voltage and current levels. Be sure to carefully follow the following instructions for all the terminal connection.

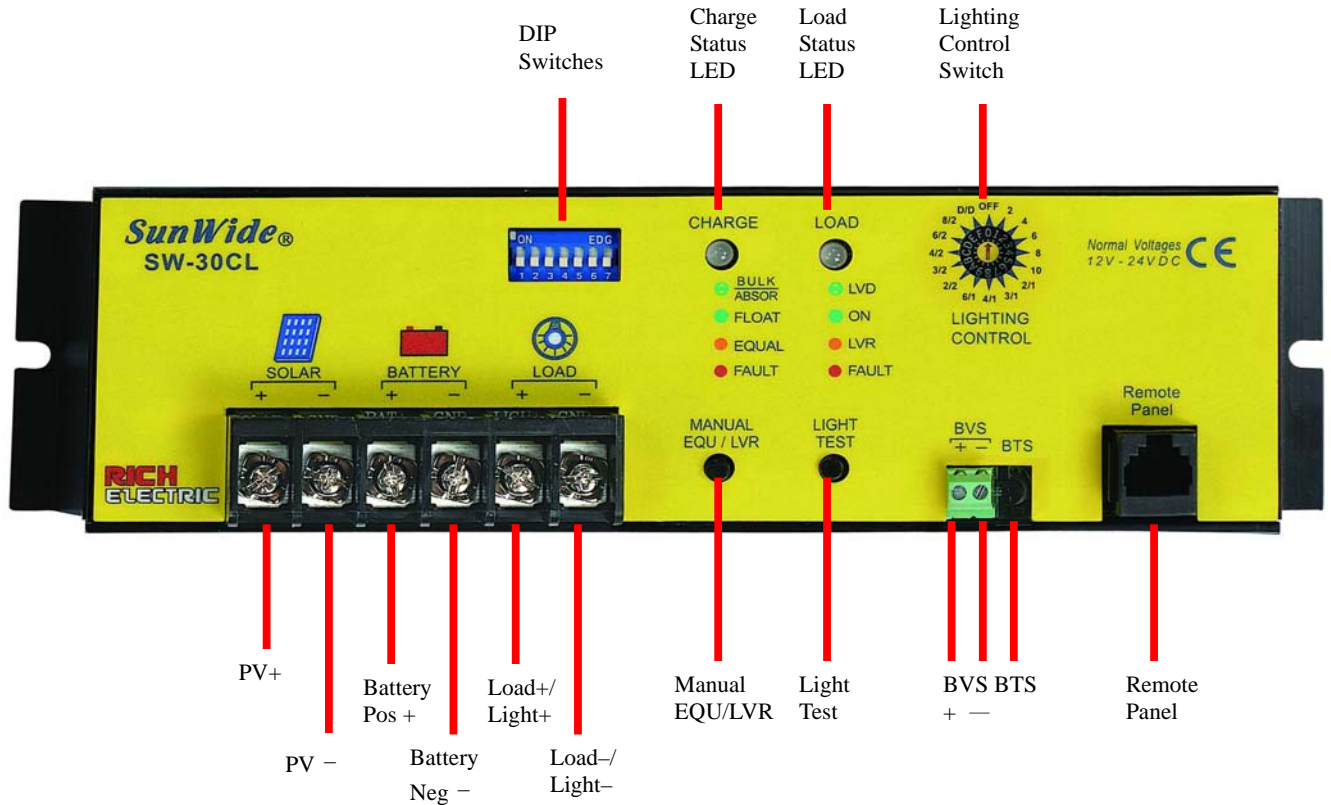

Control Terminal Connection

Name	Description
PV+	Connecting terminal for Solar Array Positive
PV -	Connecting terminal for Solar Array Negative
Battery +	Connecting terminal for Battery cable Positive
Battery -	Connecting terminal for Battery cable Negative
Load + / Light +	Connecting terminal for DC Load / Light Positive
Load- / Light -	Connecting terminal for DC load / Light Negative
Dip Switch 1, 2	Selection of battery voltage for 12V or 24V or 48V system
Dip Switch 3, 4, 5,	Battery charge control mode: Battery charging algorithm
Dip Switch 6	Battery charge control mode: Auto / Manual Equalization
	Load control mode: Auto / Manual Reconnect

Dip Switch 7	ON: Lighting control OFF: Load Control	
Lighting control Switch	OFF:	Lights remain turned off.
	2,4,6,8,10:	Hours light is turned on after sunset.
	2/1, 3/1, 4/1, 6/1, 2/2, 3/2, 4/2, 6/2, 8/2:	Light is turned on after sunset, turned off after the selected lasting hours, and turned on again before sunrise. 2/1: Light is turned on for two hours after sunset, turned off after two hours and turned on again one hour before sunrise.
	D/D:	Dusk-to-Dawn, light is on all night
Remote Panel	Connecting port for the optional LCD remote panel for SW-30CL model	
BVS + / -	Connecting terminal for Battery Voltage Sensor to compensate for voltage loss due to cable resistance.	
BTS	Battery Temperature Sensor is built in SunWide for temperature compensation	

LED Status Indicators

Charge Status LED	<p>Blinking Green: Charging is in the state of Bulk or Absorption Solid Green: Charging is in the state of Float Solid Orange: Charging in the state of Equalization Solid Red: Charging in the state of fault: Over Current Blinking Red: Charging in the state of fault: Over Temp. ※ SunWide units do the auto detection for day and night with the solar array for the first day of installation so every SunWide unit must go through the following two procedures when used in “Light Control Mode”. Blinking Green/Red by turns: The solar array has been detected to be less than 6V for lasting 10 minutes and SunWide recognizes the time as nighttime. Blinking Orange/Green by returns: The solar array has been detected to be more than 10V for lasting 10 minutes and SunWide recognizes the time as daytime.</p>
Load Status LED	<p>Blinking Green: If the battery charge state falls below the disconnect setpoint voltage (Initial setting: 11.1V for 12V system, 22.2V for 24V system and 44.4V for 48V system) lasting for six minutes, the green LED will blink to be ready for load disconnection. Solid Orange: After six minutes of battery voltage under setpoint, the orange LED will lit to show the low voltage disconnection for loads. Blinking Orange: When the battery voltage recovers to above the reconnect setpoint (Initial setting: 12.6V for 12V system, 25.2V for 24V system and 50.4V for 48V system), the orange LED will blink to be ready for reconnection for six minutes.</p>

	<p>Solid Green: Battery discharges to DC load; after six minutes of reconnection process, the green LED will be lit to show battery successfully discharges to DC load</p> <p>Solid Red: Load control in fault: Load Over Current</p> <p>Blinking Red: Load control in fault: Over Temperature</p>
--	---

Push Buttons

Light Test	<p>Press the Light Test Push Button to enter the testing mode to check if the Lighting Control Switch has been correctly set in order to control the lights based on desired timer.</p> <p>Procedure:</p> <ol style="list-style-type: none"> 1. Select Dip Switch 7 to be ON 2. Press LIGHT TEST push button until the LOAD LED blinking in green and red in turns. 3. The light will be lit on when the power circuit is operating well. 4. Press LIGHT TEST push button to return to charge battery/load control state.
<i>PUSH</i> Manual Equalize/LVR	When there is a fault occurring, push Manual Equalize/LVR to reset it.
<i>HOLD</i> Manual Equalize/LVR	Battery charge control mode: Hold Manual Equalize/LVR to start equalization and press it again to stop equalization.

❖ Optional Remote LCD Meter for SW-30CL and SW-45CL

One Remote LCD Meter can be added to the SW-30CL at any time during or after installation. The display is a 2x16 LCD meter with backlighting. One pushbuttons is used to scroll through the displays function.

There are a series of display screens that provide information such as:

- Operating information and data
- Reset Amp-Hours



1-7 Installation Steps:

This section provides a brief overview of how to get started using the SunWide controller. However, please review the entire manual to ensure best performance and years of trouble-free service.

NOTES:

- The SunWide prevents reverse current leakage at night, so a blocking diode is not required in the system.
- The connector terminals will accept a maximum wire size of AWG #10 (up to 5.2 mm²). A flathead screwdriver is required. (Some #10 spade connectors may not fit in this terminal.)
- Tighten each terminal clamping screw to 20 inch-pounds of torque.
- The SunWide is designed to regulate power from a PV array. Other generators can be connected directly to the battery, however, with no effect on the SunWide.

STEPS:

1. Mount the SunWide on to a vertical surface. Allow a minimum of 5 cm (2 inches) space above and below the controller for air flow.
2. Make sure the PV and load currents will not exceed the ratings of the SunWide model being installed.
3. The connections to the SunWide terminals are shown in the panel drawing.

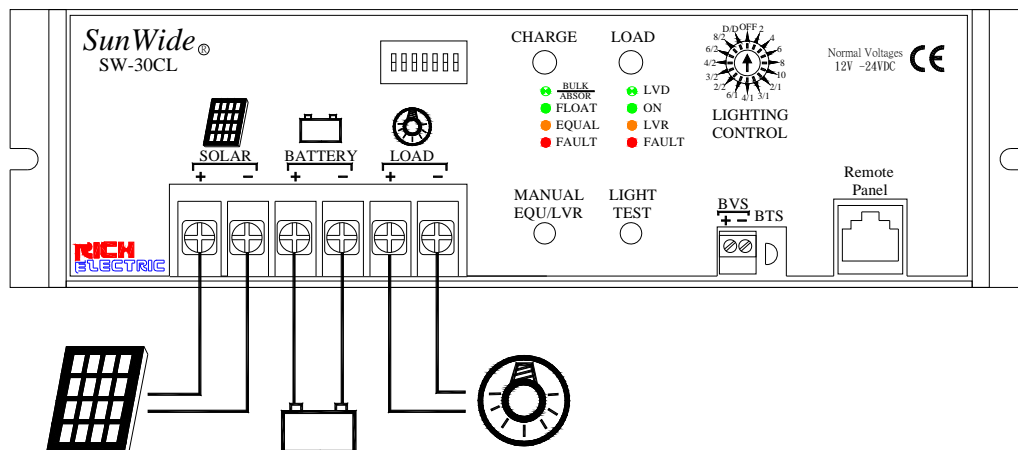

4. Connect the **BATTERY** first. Be careful that bare wires do not touch the metal case of the controller.
 - ✘ The BATTERY must be connected before the SOLAR to properly start the microcontroller.
 - ✘ If the battery voltage is below LVD (low voltage disconnect) which can be selected by MANUAL EQU/LVR and LIGHT TEST buttons, the load has been automatically disconnected due to a very low battery charge condition, and the battery must be recharged.
 - ✘ A battery below 10 volts may not start the microcontroller properly. Make sure the battery is charged before installing the system.
5. Connect the **SOLAR** (PV array) next. The green LED indicator will light if the array is

connected during the daytime and the array is wired correctly.

- ※ If the SOLAR is disconnected during installation, the controller will see this as the first night and the length of night will be too short. This will only affect ON/OFF/ON settings, and will automatically be corrected over 4 days. If the PV array is disconnected, it is best to disconnect the battery and restart the microcontroller before leaving the site.
 - ※ Remember that the Solar array will generate power whenever in sunlight. Also, be careful not to shortcircuit the PV array while connected to the controller, since this will damage the controller.
6. Connect the **LIGHT** last. If the red LED indicator lights, the battery capacity is low and should be charged before completing the system installation
 7. Set the DIP Switch 1 and 2 for the voltage system, set the DIP Switch 3, 4, 5 for battery charging algorithm, set the DIP Switch 6 for Auto/Manual Equalization or Load reconnect, set the DIP Switch 7 for Light or Load Control
 8. For most effective surge protection, it is recommended that the negative system conductor be properly grounded.
 9. Turn the rotary LIGHTING CONTROL switch to the lighting option desired.

2-1 Operating Modes

There are three distinct operating modes programmed into each SunWide. Different from SunStar, only one mode of operation being selected for an individual unit, SunWide can be operated at Solar Battery Charging mode and DC Load Control or Lighting control mode at the same time.

Solar Battery Charging

The energy output of a solar array is used for recharging the system battery.

The SunWide manages the charging process to be efficient and to maximize the life of the battery. Charging includes a bulk charging stage, PWM absorption, float and equalization.

DC Load Control

When set for DC load control, the SunWide powers loads from the battery, and protects the battery from over-discharge with a current compensated LVD (low voltage load disconnect).

Lighting Control

When set for lighting control, the SunWide would detect day and night and measure the length of night at different time and area zone. The desired lighting hours can be set for the precise control to turn on and turn off the light in order to achieve power saving.

2-2 Adjustability of Solar Battery Charging

Seven DIP switches permit the following parameters to be adjusted at the installation site:

DIP Switch	Solar battery charging
1	Select Battery Voltage
OFF	48V system
ON	24V system
OFF	12V system

3~5	Standard battery charging programs
6 (OFF)	Manual Equalization
(ON)	Auto Equalization
7 (OFF)	Load Control
(ON)	Lighting control

PWM Battery Charging

PWM (Pulse Width Modulation) battery charging is the most efficient and effective method for recharging a battery in a solar system.

Selecting the best method for charging your battery together with a good maintenance program will ensure a healthy battery and long service life. Although the SunWide's battery charging is fully automatic, the following information is important for getting the best performance from your SunWide controller and battery.

Four Stages of Solar Charging

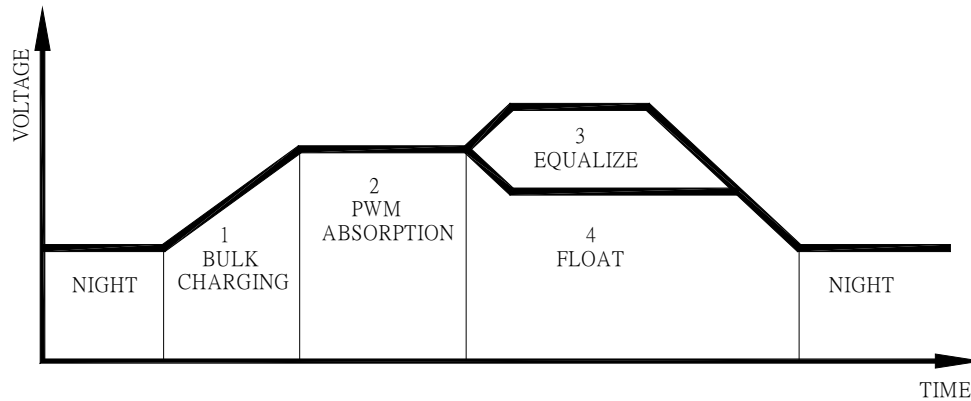

Solar Charging Stages

- 1. Bulk Charging:** In this stage, the battery will accept all the current provided by the solar system.
- 2. PWM Absorption:** When the battery reaches the regulation voltage, the PWM begins to hold the voltage constant. This is to avoid over-heating and over-gassing the battery. The current will taper off to safe levels as the battery becomes more fully charged.
- 3. Equalization:** Many batteries benefit from a periodic boost charge to stir the electrolyte, level the cell voltages, and complete the chemical reactions.
- 4. Float:** When the battery is fully recharged, the charging voltage is reduced to prevent further heating or gassing of the battery.

Battery Charging Notes

The SunWide manages many different charging conditions and system configurations. Some useful functions to know follow below.

Solar Overload: Enhanced radiation or “edge of cloud effect” conditions can generate more current than the controller’s rating. The SunWide will reduce this overload up to 130% of rated current by regulating the current to safe levels. If the current from the solar array exceeds 150%, the controller will interrupt charging.

Battery Temperature Compensation: All charging setpoints are based on 25°C (77°F). If the battery temperature varies by 5°C, the charging will change by 0.15 volts for a 12 volt battery. This is a substantial change in the charging of the battery.

Day-Night Detection: The SunWide will automatically detect day and night conditions. Any functions that require measuring time or starting at dawn, for example, will be automatic.

Battery Types: The SunWide’s standard battery charging programs are suitable for a wide range of lead-acid battery types. These standard programs are select by DIP Switch 3~5.

Standard Battery Charging Programs

The SunWide provides 8 standard battery charging algorithms (programs) that are selected with the DIP switches. These standard algorithms are suitable for lead-acid batteries ranging from sealed (gel, AGM, maintenance free) to flooded to L-16 cells and Ni-cad etc.

The table below summarizes the major parameters of the standard charging algorithms. Note that all the voltages are for 12V systems (24V = 2X, 48V = 4X).

All values are 25°C (77°F).

DIP Switches (3-4-5)	A Battery Type	B Bulk Voltage	C Float Voltage	D Equalize Voltage	E Equalize Time (hours)	F Equalize Interval (days)
off-off-off	1 – Sealed	14.0	13.4	None	-	-
off-off-on	2 – Sealed	14.1	13.4	14.2	1	28
off-on-off	3 - Sealed	14.3	13.4	14.4	2	28
off-on-on	4 - Flooded	14.4	13.4	15.1	3	28
on-off-off	5 - Flooded	14.6	13.4	15.3	3	28
on-off-on	6 - Flooded	14.8	13.4	15.3	3	28
on-on-off	7 - L-16	15.0	13.4	15.3	3	14
on-on-on	8-NiCad	16.0	14.5	None	-	-

Standard Battery Charging Programs

A. Battery Type– These are generic lead-acid and Ni-cad battery types.

B. BULK Voltage–This is the PWM Absorption stage with constant voltage charging. The “PWM voltage” is the maximum battery voltage that will be held constant. As the battery becomes more charged, the charging current tapers off until the battery is fully charged.

C. Float Voltage–When the battery is fully charged, the charging voltage will be reduced to 13.4 volts for all battery types.

D. Equalization Voltage–During an equalization cycle, the charging voltage will be held constant at this voltage.

E. Equalization Time–The charging at the selected equalization voltage will continue for this number of hours. This may take more than one day to complete.

F. Equalization Interval—Equalizations are typically done once a month. Most of the cycles are 28 days so the equalization will begin on the same day of the month. It can be set by Dip Switch 3~5 for different interval days. Each new cycle will be reset as the equalization starts so that a setting day period will be maintained.

Temperature Effects

Battery Temperature Sensor (BTS)

A sensor next to the remote panel is used for temperature compensated battery charging. As the battery gets warmer, the gassing increases. As the battery gets colder, it becomes more resistant to charging. Depending on how much the battery temperature varies, it may be important to adjust the charging for temperature changes.

There are three battery charging parameters that are affected by temperature:

PWM Absorption

This is the most important part of charging that is affected by temperature because the charging may go into PWM absorption almost every day. If the battery temperature is colder, the charging will begin to regulate too soon and the battery may not be recharged with a limited solar resource. If the battery temperature rises, the battery may heat and gas too much.

Equalization

A colder battery will lose part of the benefit of the equalization. A warmer battery may heat and gas too much.

Float

Float is less affected by temperature changes, but it may also undercharge or gas too much depending on how much the temperature changes.

The BTS corrects the three charging setpoints noted above by the following values:

- 12 volt battery: -0.030 volts per $^{\circ}\text{C}$ (-0.017 volts per $^{\circ}\text{F}$)
- 24 volt battery: -0.060 volts per $^{\circ}\text{C}$ (-0.033 volts per $^{\circ}\text{F}$)
- 48 volt battery: -0.120 volts per $^{\circ}\text{C}$ (-0.067 volts per $^{\circ}\text{F}$)

Variations in battery temperature can affect charging, battery capacity, and battery life. The greater the range of battery temperatures, the greater the impact on the battery. For example, if the temperature falls to 10°C (50°F) this 15°C (27°F) change in temperature will change the PWM, equalization and float setpoints by 1.80V in a 48V system.

Temperature	12 Volt	24 Volt	48 Volt
$50^{\circ}\text{C} / 122^{\circ}\text{F}$	-0.75 V	-1.50 V	-3.00 V
$45^{\circ}\text{C} / 113^{\circ}\text{F}$	-0.60 V	-1.20 V	-2.40 V
$40^{\circ}\text{C} / 104^{\circ}\text{F}$	-0.45 V	-0.90 V	-1.80 V
$35^{\circ}\text{C} / 95^{\circ}\text{F}$	-0.30 V	-0.60 V	-1.20 V
$30^{\circ}\text{C} / 86^{\circ}\text{F}$	-0.15 V	-0.30 V	-0.60 V
$25^{\circ}\text{C} / 77^{\circ}\text{F}$	0 V	0 V	0 V
$20^{\circ}\text{C} / 68^{\circ}\text{F}$	$+0.15\text{ V}$	$+0.30\text{ V}$	$+0.60\text{ V}$
$15^{\circ}\text{C} / 59^{\circ}\text{F}$	$+0.30\text{ V}$	$+0.60\text{ V}$	$+1.20\text{ V}$

10°C / 50°F	+ 0.45 V	+ 0.90 V	+ 1.80 V
5°C / 41°F	+ 0.60 V	+ 1.20 V	+ 2.40 V
0°C / 32°F	+ 0.75 V	+ 1.50 V	+ 3.00 V

Temperature Compensation

Equalization

Routine equalization cycles are often vital to the performance and life of a battery — particularly in a solar system. During battery discharge, sulfuric acid is consumed and soft lead sulfate crystals form on the plates. If the battery remains in a partially discharged condition, the soft crystals will turn into hard crystals over time. This process, called “lead sulfation,” causes the crystals to become harder over time and more difficult to convert back to soft active materials.

Sulfation from chronic undercharging of the battery is the leading cause of battery failures in solar systems. In addition to reducing the battery capacity, sulfate build-up is the most common cause of buckling plates and cracked grids. Deep cycle batteries are particularly susceptible to lead sulfation.

Normal charging of the battery can convert the sulfate back to the soft active material if the battery is fully recharged. However, a solar battery is seldom completely recharged, so the soft lead sulfate crystals harden over a period of time. Only a long controlled overcharge, or equalization, at a higher voltage can reverse the hardening sulfate crystals.

In addition to slowing or preventing lead sulfation, there are also other benefits from equalizations of the solar system battery. These include:

Balance the individual cell voltages.

Over time, individual cell voltages can drift apart due to slight differences in the cells. For example, in a 12 cell (24V) battery, one cell is less efficient in recharging to a final battery voltage of 28.8 volts (2.4 V/c). Over time, that cell only reaches 1.85 volts, while the other 11 cells charge to 2.45 volts per cell. The overall battery voltage is 28.8V, but the individual cells are higher or lower due to cell drift. Equalization cycles help to bring all the cells to the same voltage.

Mix the electrolyte.

In flooded batteries, especially tall cells, the heavier acid will fall to the bottom of the cell over time. This stratification of the electrolyte causes loss of capacity and corrosion of the lower portion of the plates. Gassing of the electrolyte from a controlled overcharging (equalization) will stir and remix the acid into the battery electrolyte.

NOTE: Excessive overcharging and gassing too vigorously can damage the battery plates and cause shedding of active material from the plates. An equalization that is too high or for too long can be damaging. Review the requirements for the particular battery being used in your system.

Standard Equalization Programs

Both automatic and manual equalizations can be performed using the standard charging programs.

Manual Equalization

The SunWide is shipped with the DIP switch set for manual equalization only. This is to avoid an unexpected or unwanted automatic equalization. In the manual mode, the pushbutton is used to both start or stop a manual equalization. Hold the pushbutton down for 5 seconds to start or stop an equalization (depending on whether an equalization is in progress or not).

There are no limits to how many times the pushbutton can be used to start and stop equalizations. Equalizations will be terminated automatically as per the charging program selected if the pushbutton is not used to manually stop the equalization.

Automatic Equalization

If the equalization DIP switch is moved to the ON position), the equalizations will begin automatically as per the charging program selected. Other than starting, the automatic and manual equalizations are the same and follow the standard charging program selected. The pushbutton can be used to start and stop equalizations in both the manual and automatic mode.

Typical Equalizations

The automatic equalizations will occur at the selected charging program from Dip Switch 3~5. When an equalization begins (auto or manual), the battery charging voltage increases up to the equalization voltage (Veq). The battery will remain at Veq for the time specified in the selected charging program.

The equalization process will continue until the voltage has been held above the bulk setting for a cumulate period of two hours. A second manual equalization cycle can be started with the pushbutton if needed.

If the equalization cannot be completed in one day, it will continue the next day or days until finished. After an equalization is completed, charging will return to PWM absorption.

When to Equalize

The ideal frequency of equalizations depends on the battery type (leadcalcium, lead-antimony, etc.), the depth of discharging, battery age, temperature, and other factors.

One very broad guide is to equalize flooded batteries every 1 to 3 months or every 5 to 10 deep discharges. Some batteries, such as the L-16 group, will need more frequent equalizations.

The difference between the highest cell and lowest cell in a battery can also indicate the need for an equalization. Either the specific gravity or the cell voltage can be measured.

The battery manufacturer can recommend the specific gravity or voltage values for your particular battery.

Float

When a battery becomes fully charged, dropping down to the float stage will provide a very low rate of maintenance charging while reducing the heating and gassing of a fully charged battery. When the battery is fully recharged, there can be no more chemical reactions and all the charging current is turned into heat and gassing.

The purpose of float is to protect the battery from long-term overcharge. From the PWM absorption stage, charging is dropped to the float voltage. This is typically 13.4V.

2-3 Adjustability of Load Control

When setting in the load control mode, DIP Switch 7 should be placed at OFF. The LVD (low voltage disconnect) and LVR (low voltage reconnect) are important setpoints to protect the system battery from deep discharges that could damage the battery.

The Procedure of LVD/LVR Selection

Step 1: Press MANUAL EQU/LVR push button and LIGHT TEST push button at the same time until the CHARGE LED turns red and LOAD LED turns green in turns.

Step 2: Press LIGHT TEST push button at one time and observe the CHARGE LED color and LOAD LED color changing in the following order to select the LVD and LVR level.

CHARGE LED	LOAD LED	LVR			LVD		
Voltage System		12V	24V	48V	12V	24V	48V
Red	Red	12.6	25.2	50.4	11.1	22.2	44.4
Red	Green	12.8	25.6	51.2	11.3	22.6	45.2
Green	Red	13.0	26.0	52.0	11.5	23.0	46.0
Green	Green	13.2	26.4	52.8	11.7	23.4	46.8
Green	Orange	13.4	26.8	53.6	11.9	23.8	47.6
Orange	Green	13.6	27.2	54.4	12.1	24.2	48.4
Orange	Orange	13.8	27.6	55.2	12.3	24.6	49.2
Orange	Red	12.0	24.0	48.0	10.5	21.0	42.0

Step 3: Press MANUAL EQU/LVR to finish the LVD/LVR level setting procedure.

Inductive Loads (Motors)

For dc motors and other inductive loads, it is strongly recommended to install a diode near the controller. Inductive loads can generate large voltage spikes that might damage the controller's lightning protection devices.

The diode should be installed near the controller, and in the orientation shown in the diagram below:

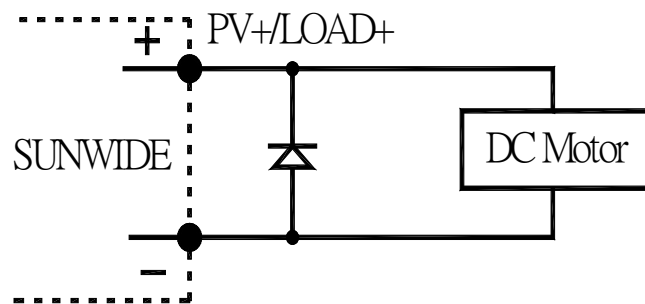

Diode Protection

The specifications for the diode follow:

- a power diode
- rated equal or greater than 80 volts
- rated equal or greater than 10 amps (SW-10CL) or 20 amps (SW-20CL) or 30 amps (SW-30CL)

For large inductive loads, a heat sink for the diode may be necessary.

General Load Control Notes

In addition to the inductive loads discussed above, there are a few other load issues that require attention:

Inverters

Inverters should never be connected to the SunWide

Reverse Polarity

If the battery is correctly connected (LEDs are on), the load should be connected very carefully with regard to polarity (+ / -).

If the polarity is reversed, the controller cannot detect this. There are no indications. Loads without polarity will not be affected.

Loads with polarity can be damaged. It is possible that the SunWide will go into short circuit protection before the load is damaged. If the LEDs indicate a "Fault", be certain to check for both shorts and reversed polarity connections.

If the controller does not go into short circuit protection, the loads with polarity will be damaged.

CAUTION: Carefully verify the polarity (+ and -) of the load connections before applying power to the controller.

2-4 Adjustability of Lighting Control

When setting in the lighting control mode, DIP Switch 7 should be placed at ON. After completing the system connections, select the desired LIGHTING CONTROL switch option. The brief description of the options follows below:

Lighting control Switch	OFF:	Lights remain turned off.
	2,4,6,8,10:	Hours light is turned on after sunset.
	2/1, 3/1, 4/1, 6/1, 2/2, 3/2, 4/2, 6/2, 8/2:	Light is turned on after sunset, turned off after the selected lasting hours, and turned on again before sunrise. 2/1: Light is turned on for two hours after sunset, turned off after two hours and turned on again one hour before sunrise.
	D/D:	Dusk-to-Dawn, light is on all night

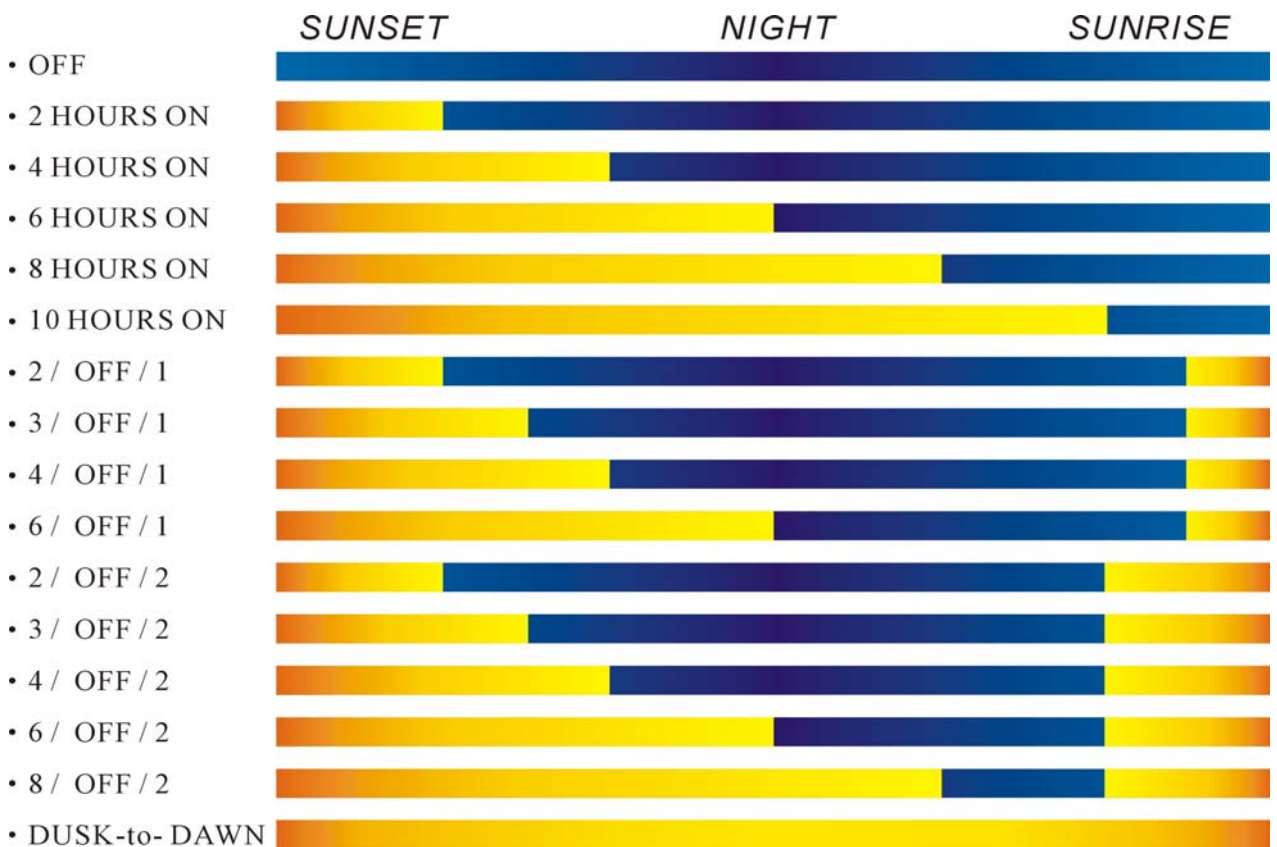

To select a lighting control option, turn the rotary digital switch to the desired position. An arrow in the rotary switch will point to the selected position. This is a digital switch, so it will click into each of the sixteen positions.

To confirm correct selection of the desired control option, press the LIGHT TEST button to enter the testing mode.

LIGHT TEST Button

Press the LIGHT TEST button to enter the testing mode to check if the Lighting Control Switch has been correctly set in order to control the lights based on desired timer. The procedure is listed as below.

STEPS:

1. Select Dip Switch 7 to be ON
2. Press LIGHT TEST push button until the LOAD LED blinking in green and red in turns.
3. The light will be lit on when the power circuit is operating well.
4. Press LIGHT TEST push button to return to charge battery/load control state.

Auto Detector for Day and Night

The SunWide uses the solar array to detect day and night. The transition to night requires the solar panel delivering less than 6Vdc lasting for 10 minutes. The transition back to day requires the solar panel delivery more than 10Vdc lasting for 10 minutes. Both state changes require 10 minutes of continuous transition values before making the change. These constraints avoid false transitions due to lightning or dark storm clouds.

Measure Night Length

The LIGHTING CONTROL options that turn the lights on again before sunrise require that the SunWide measure the length of the night. Therefore, the controller cannot turn the lights on before sunrise the first night after installation (or after reconnecting the battery). If the solar array is disconnected during service, the controller will then measure a faulty night length. Either reset the controller by reconnecting the battery, or this short “night” will be automatically corrected by the controller after **4 days** of service.

NOTE: The SunWide uses the open circuit voltage of the PV panel to determine the correct time for dawn and dusk. If the PV panel is covered with debris (e.g. snow, leaves, dirt), the PV panel voltage may be too low which can cause load timing errors. If the load is operating erratically, make sure the PV panels are clean, there are no obstructions shading the array, and the PV panels are oriented to the sun correctly. The SunWide will automatically correct load timing errors within 4 days of clearing the array.

2-5 Troubleshooting

The SunWide is very rugged and designed for the most extreme operating conditions. Most PV system problems will be caused by connections, voltage drops, and loads. Troubleshooting the SunWide controller is simple. Some basic troubleshooting procedures are listed below.

CAUTIONS:

1. Troubleshooting should be done by qualified personnel only.
2. Remember that a battery can cause serious damage if shorted.
3. There are no user serviceable parts, fuses or circuit breakers inside the SunWide.
4. Observe all normal precautions when working with energized circuitry.

1. BATTERY IS NOT CHARGING

- Check the green LED indicator. The green CHARGING LED should be on if it is daytime.
- Check that the proper battery charging has been selected by DIP Switches.
- Check that all wire connections in the system are correct and tight. Check the polarity (+ and –) of the connections.
- Measure the PV array open-circuit voltage and confirm it is within normal limits. If the voltage is low or zero, check the connections at the PV array itself. Disconnect the PV from the controller when working on the PV array.
- Check that the load is not drawing more energy than the PV array can provide.
- Check if there are excessive voltage drops between the controller and the battery. This will cause undercharging of the battery.
- Check the condition of the battery. Determine if the battery voltage declines at night with no load. If unable to maintain its voltage, the battery may be failing.
- Measure the PV voltage and the battery voltage at the SunWide terminals. If the voltage at the terminals is the same (within a few tenths of volts) the PV array is charging the battery. If the PV voltage is close to the open circuit voltage of the panels and the battery voltage is low, the controller is not charging the batteries and may be damaged.

2. BATTERY VOLTAGE IS TOO HIGH

- First check the operating conditions to confirm that the voltage is higher than specifications.
- Check that the proper battery charging has been selected by DIP Switches.
- Check that all wire connections in the system are correct and tight.
- Disconnect the PV array and momentarily disconnect the lead from the BATTERY positive terminal. Reconnect the battery terminal and leave the PV array disconnected. The Green charging light should not be lit. Measure the voltage at the SOLAR terminals (with the array still disconnected). If the Green charging light is on or battery voltage is measured at the SOLAR terminals, the controller may be damaged.

3. LOAD NOT OPERATING PROPERLY

- Press the LIGHT TEST button to turn the lights on. This will assist in

troubleshooting the problem.

- Check that the load is turned on. Check that no system fuses are defective. Check that no system circuit breakers are tripped. Remember that there are no fuses or circuit breakers inside the SunWide.
- Check connections to the load, and other controller and battery connections. Make sure voltage drops in the system wires are not too high.
- Check for proper LED indications on the SunWide. If the solid orange LOAD DISCONNECT LED is on, the load has been disconnected due to low battery voltage. This is generally a normal state when the load exceeds the PV array output due to weather and other sunlight conditions.
- Check the PV array voltage under direct sun, with the array leads disconnected. The voltage should be close to the expected open circuit voltage for the panel type used.
- Visually inspect the PV array and verify that the array is clear of debris (e.g. leaves, snow, dirt) and that it is oriented correctly for the installation location
- Measure the voltage at the controller BATTERY terminals. If this voltage is above the LVD, the load should have power. Press the MANUAL EQU/LVR button and then measure the voltage at the controller LOAD terminals, and if there is no voltage present, the controller may be defective.